



## INSTALLATION INSTRUCTIONS REMOTE OIL TANK KIT

### APPLICATION

This instruction sheet is a guide for proper installation of components supplied in this kit. These components are designed for use on *Evinrude* and *Johnson* outboards. Refer to service manual and installation guides for additional assembly information.

### SAFETY INFORMATION

For safety reasons, this kit should be installed by an authorized *Evinrude*®/*Johnson*® dealer. This instruction sheet is not a substitute for work experience. Additional helpful information may be found in other service literature for your engine.

This instruction sheet uses the following signal words identifying important safety messages.

	<b>DANGER</b>	
Indicates an imminently hazardous situation which, if not avoided, <b>WILL</b> result in death or serious injury.		

	<b>WARNING</b>	
Indicates a potentially hazardous situation which, if not avoided, <b>CAN</b> result in severe injury or death.		

	<b>CAUTION</b>	
Indicates a potentially hazardous situation which, if not avoided, <b>MAY</b> result in minor or moderate personal injury or property damage. It also may be used to alert against unsafe practices.		

**IMPORTANT:** Identifies information that will help prevent damage to machinery and appears next to information that controls correct assembly and operation of the product.

These safety alert signal words mean:

**ATTENTION!  
BECOME ALERT!  
YOUR SAFETY IS INVOLVED!**

Always follow common shop safety practices. If you have not had training related to common shop safety practices, you should do so to protect yourself, as well as the people around you.

It is understood that this instruction sheet may be translated into other languages. In the event of any discrepancy, the English version shall prevail.

**DO NOT** do any repairs until you have read the instructions and checked the pictures relating to the repairs.

Be careful, and never rush or guess a service procedure. Human error is caused by many factors: carelessness, fatigue, overload, preoccupation, unfamiliarity with the product, and drugs and alcohol use, to name a few. Damage to a boat and outboard can be fixed in a short period of time, but injury or death has a lasting effect.

When replacement parts are required, use *Evinrude/Johnson Genuine Parts* or parts with equivalent characteristics, including type, strength and material. Using substandard parts could result in injury or product malfunction.

Torque wrench tightening specifications must be strictly followed. Replace any locking fastener (lock-nut or patch screw) if its locking feature becomes weak. Definite resistance to turning must be felt when reusing a locking fastener. If replacement is specified or required because the locking fastener has become weak, use only authorized *Evinrude/Johnson Genuine Parts*.

If you use procedures or service tools that are not recommended in this instruction sheet, **YOU ALONE** must decide if your actions might injure people or damage the outboard.

**TO THE INSTALLER:** Give this sheet to the owner. Advise the owner of any special operation or maintenance information contained in the instructions.

**TO THE OWNER:** Save these instructions in your owner's kit. This document contains information important to the future use and maintenance of your engine.



# OIL TANK – 1.8 GALLON

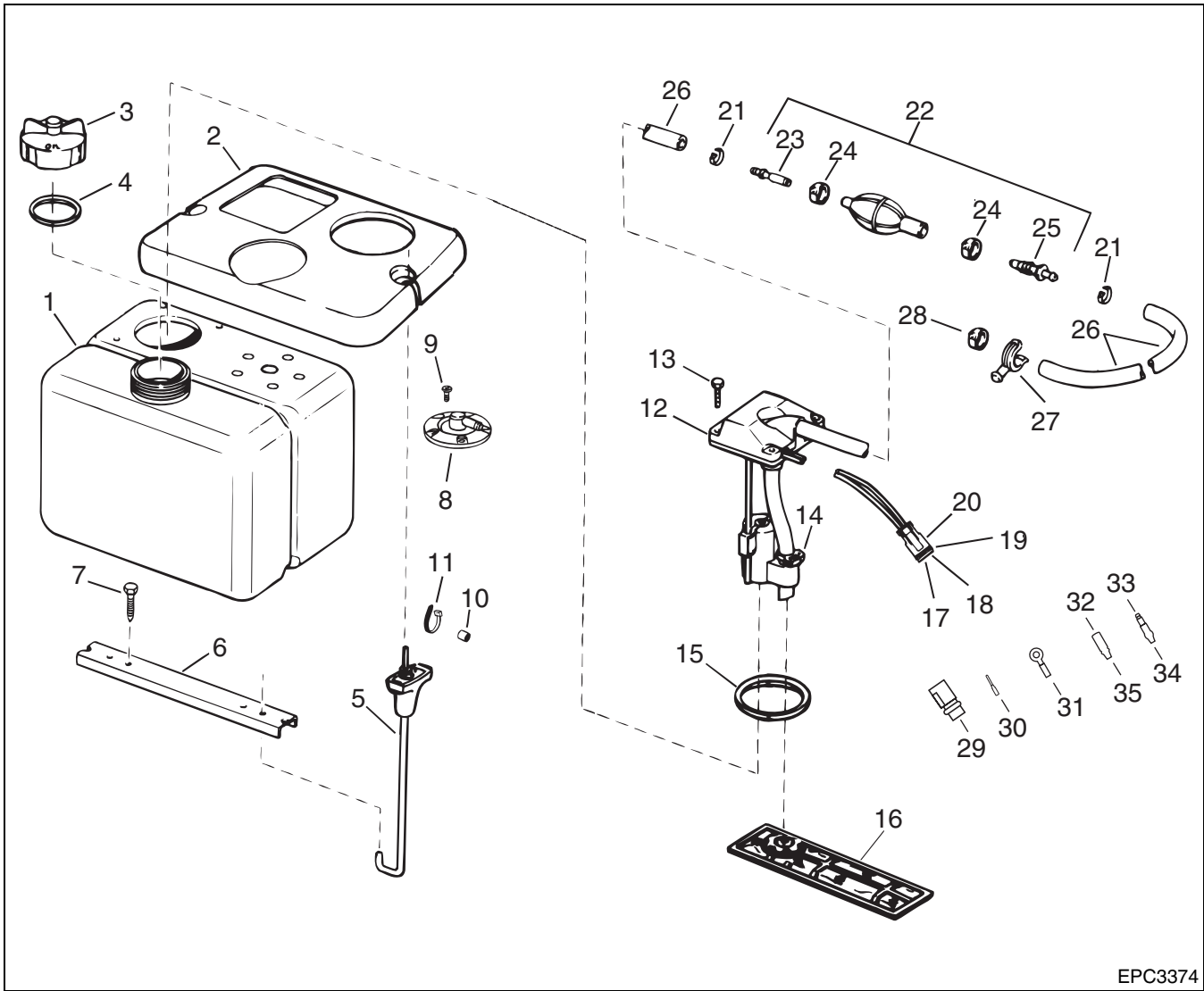

EPC3374

Ref	P/N	Name of Part	Qty	Ref	P/N	Name of Part	Qty
-	177284	OIL TANK, Assy, 1.8 Gallon	<b>New</b> 1	18	176295	**CONNECTOR, 2-pin	1
1	176712	*OIL TANK	1	19	514788	***SEAL, 2-socket	1
2	127670	*COVER, Oil tank	1	20	127287	**LOCK WEDGE, 2-socket	1
3	176217	*CAP ASSEMBLY	1	21	126945	**CLAMP, Band, small	2
4	123231	**GASKET, Cap	1	22	175985	**PRIMER BULB ASSEMBLY	1
5	175001	*ROD ASSEMBLY, Cover to bracket	2	23	436191	***NIPPLE & VALVE Assy., Inlet	1
6	124292	*BRACKET, Mounting	1	24	553166	***CLAMP, Band, Large	2
7	124073	*LAG SCREW	2	25	436145	***NIPPLE & VALVE Assy., Outlet	1
8	176724	*OIL RETURN ASSEMBLY	1	26	778707	**HOSE, Oil Supply	<b>A</b> 1
9	125529	*SCREW	5	27	329661	**HOLDER, Plug	1
10	315391	*PLUG, Oil return fitting	1	28	347108	**CLAMP, Engine oil connector	1
11	320107	*TIE STRAP	1	29	512746	**CONNECTOR, 2-pin	<b>B</b> 1
12	177285	*OIL TANK PICKUP KIT	<b>New</b> 1	30	511469	**TERMINAL, Pin	<b>B</b> 2
13	124485	**SCREW, Pickup Assy. to tank	4	31	510818	**TERMINAL, Ring	<b>B</b> 1
14	322654	**CLAMP, Snap	1	32	512876	**TERMINAL, Socket	<b>B</b> 1
15	126793	**SEAL, Pickup Assy. to tank	1	33	512947	**TERMINAL, Bullet	<b>B</b> 1
16	174377	**FILTER ASSEMBLY, Oil	1	34	513185	**SLEEVE, Bullet terminal	<b>B</b> 1
17	514680	**TERMINAL, Pin	2	35	513186	**SLEEVE, Socket	<b>B</b> 1

**A** Cut to length from bulk roll

**B** Use to adapt harness to older style wiring connectors

# OIL TANK – 3.0 GALLON

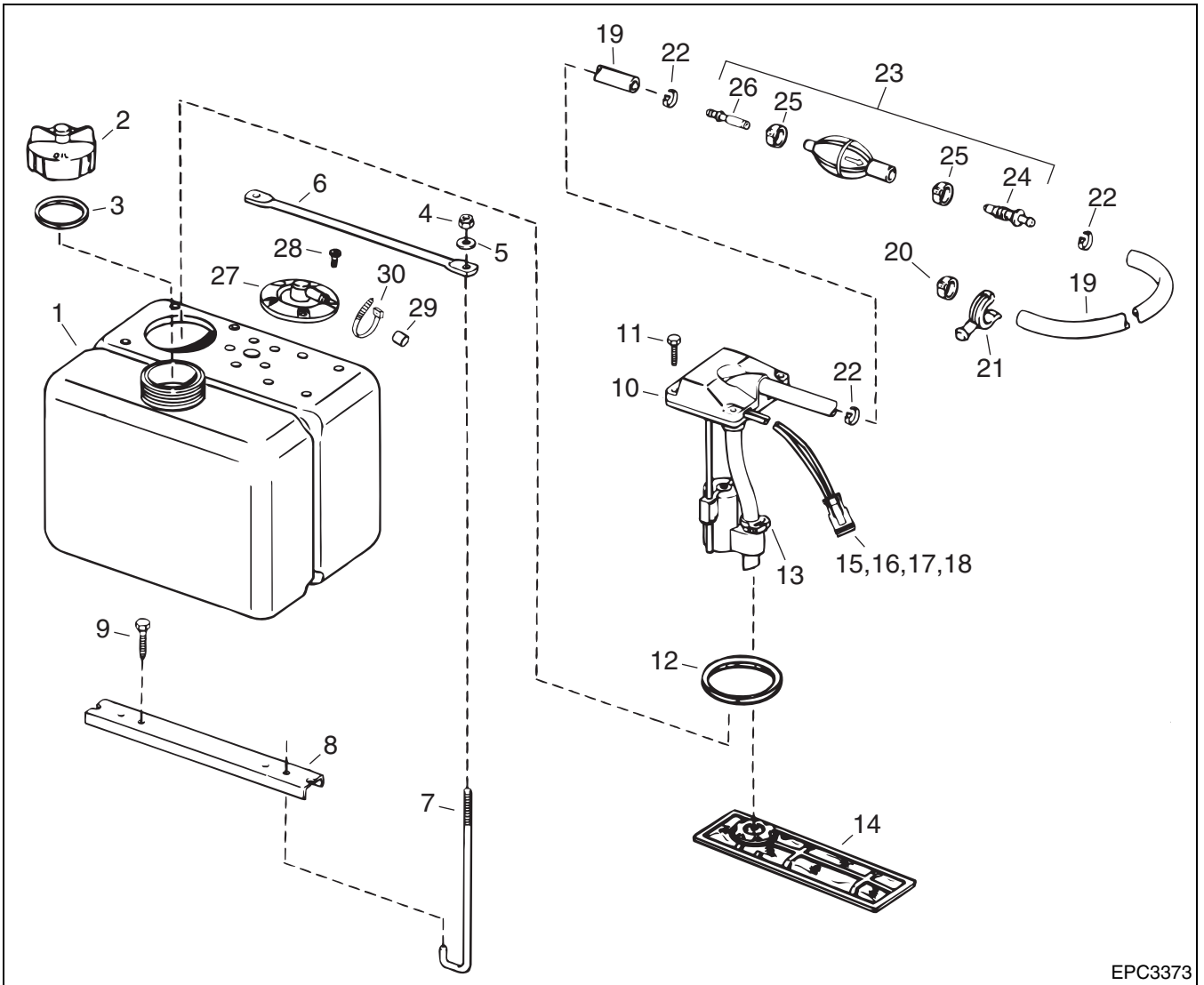

EPC3373

Ref	P/N	Name of Part	Qty	Ref	P/N	Name of Part	Qty
-	176996	OIL TANK Assy, (3.0 gallon)	1	16	514788	***SEAL, 2-socket	1
1	176722	*OIL TANK	1	17	127287	**LOCK WEDGE, 2-socket	1
2	176217	*CAP ASSEMBLY	1	18	514680	**TERMINAL, Pin	2
3	123231	**GASKET, Cap	1	19	778707	**HOSE, Oil Supply	<b>A</b> 1
4	121470	*LOCKNUT, Hook bolt to cross bar	2	20	347108	**CLAMP, Engine Oil Connector	1
5	121497	*WASHER	2	21	329661	**HOLDER, Plug	1
6	124694	*CROSS BAR	1	22	126945	**CLAMP, Band, small	2
7	124691	*HOOK BOLT	2	23	175985	**PRIMER BULB Assy.	1
8	124693	*BRACKET, Mounting	1	24	436145	***VALVE, Outlet	1
9	124073	*LAG SCREW	2	25	553166	***CLAMP, Band, large	2
10	176366	*OIL PICKUP Assy.	1	26	436191	***VALVE, Inlet	1
11	124485	**SCREW, Pickup Assy, to tank	4	27	176724	*OIL RETURN ASSEMBLY	1
12	126793	**SEAL	1	28	125529	**SCREW, Oil return	5
13	322654	**CLAMP, Snap	1	29	315391	*PLUG	1
14	174377	**FILTER ASSEMBLY, Oil	1	30	320107	*TIE STRAP	1
15	176295	**CONNECTOR, 2-pin	1				

**A** Cut to Length from bulk roll

**⚠ WARNING ⚠**

**To prevent accidental starting while servicing, disconnect battery leads from battery. Twist and remove all spark plug leads.**

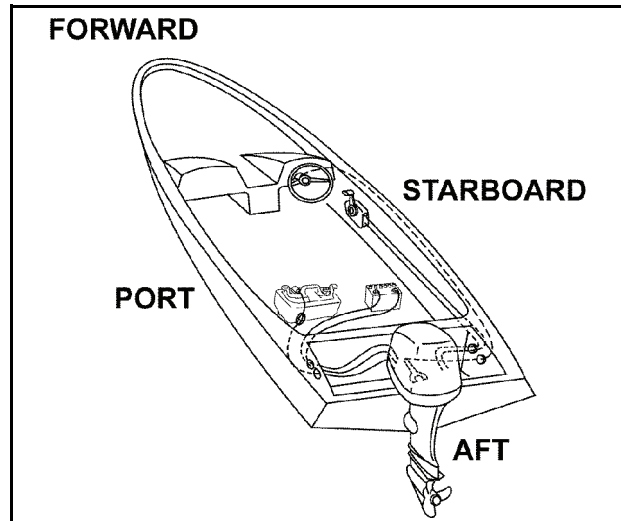

Nautical Orientation

### Oil Tank Location

**IMPORTANT:** Consider the installation location of the oil tank carefully. The oil tank is vented to the atmosphere. To avoid serious powerhead damage, be sure the oil tank is installed in a location that does not allow constant exposure to sunlight, rain, bilge water or spray.

Select mounting location which provides:

- A solid place to mount the tank;
- A dry location that prevents exposure to rain or spraying water;
- Access for adding oil;
- Access to oil-primer bulb; and
- Interference-free hose and wire routing to outboard.

Each oil tank is originally fitted with a single oil pickup assembly with 15 ft. (4.5 m) of oil supply hose and 17 ft. (5.2 m) of sending unit wiring harness.

If necessary, the oil tank can be mounted further from the outboard than the supplied hose and harness allow. The maximum length of oil supply hose that can be fitted to the oil tank is 25 ft. (7.6 m).

**IMPORTANT:** Do not add hose to an existing oil supply hose.

If the oil tank requires more than 15 ft. (4.5 m) of oil supply hose:

- Oil supply hose from primer bulb to outboard must be one continuous length of 1/4 in. (6.4 mm) hose.
- Maximum length for hose is 25 ft. (7.6 m).
- Replacement hose must be designated for fuel or oil use and approved for marine use.
- Extend wiring harness with 16 gauge AWG wire.
- Protect connections with heat shrink tube.
- Maintain wire color and polarity when extending harness.

An appropriately sized battery box may be used to conceal and protect the oil tank, if desired.

**IMPORTANT:** Be sure box includes drain holes so it does not fill with water and contaminate oil.



000074

### Oil Tank Mounting

Place tank in selected position. Mark one line under groove in tank bottom and one line at each end of tank as shown.

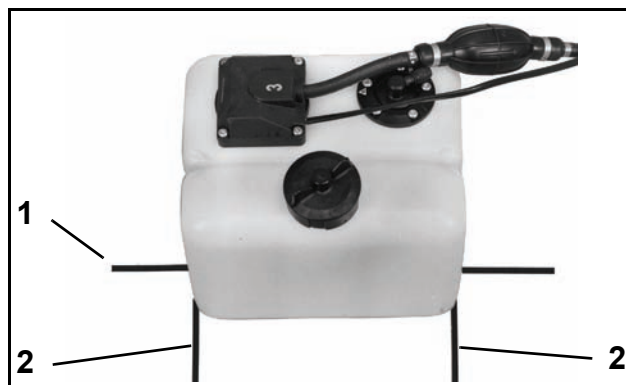

1. Groove of tank
2. End of tank

44737

**IMPORTANT:** Make sure mounting hole locations provide enough clearance for mounting screws. Screws should not contact or penetrate boat hull.

Place mounting bracket on center line between end lines. Use the inner bracket holes as guides to drill two 5/32 in. (4 mm) pilot holes.



COB5381

### 1.8 Gallon Tank

Place rods into mounting bracket and secure with lag screws.

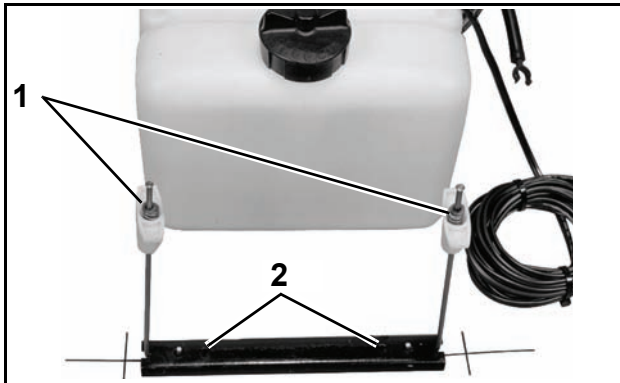

1. Rods  
2. Screws  
22149A

Place oil tank onto mounting bracket. If cover is not pre-assembled, route oil supply hose and harness through the cover and position cover on the oil tank. Attach spring-loaded rods to cover as shown.

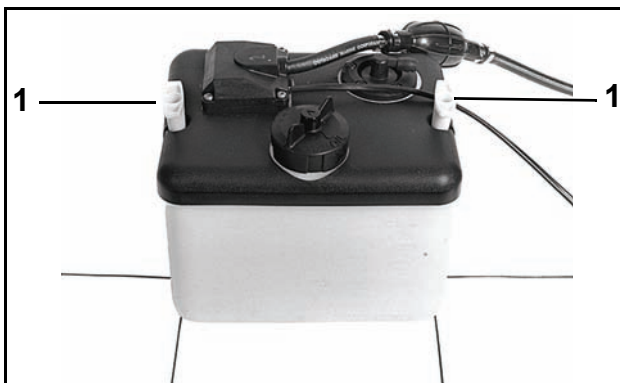

1. Rods  
48704

### 3 Gallon (11.4 L) Tank

Place rods into mounting bracket and secure lag screws.

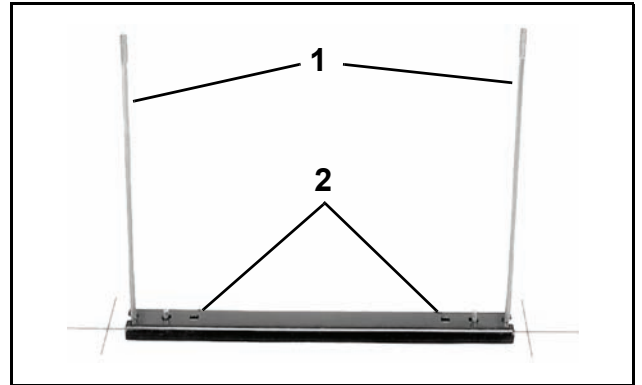

1. Rods  
2. Screws  
22241B

Place oil tank onto mounting bracket. Assemble crossbar onto rods, install flat washers and locknuts. Tighten locknuts to secure tank.

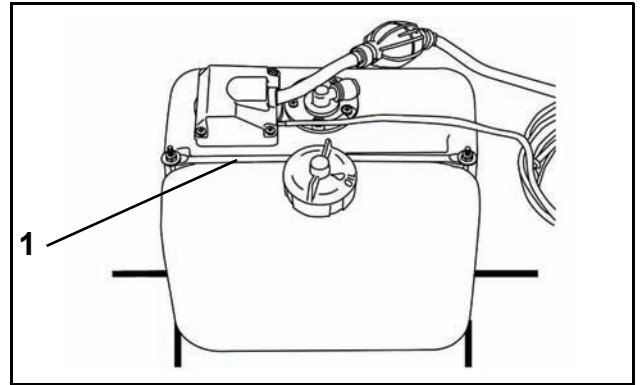

1. Crossbar  
DRC7418

## Oil Supply Hose Routing

**IMPORTANT:** Refer to appropriate service manual or the *Installation and Predelivery Guide* for additional installation and rigging information.

Oil hose installation requirements:

- Route hose from oil tank to engine. Maximum length for hose is 25 ft. (7.6 m).
- DO NOT allow hose to be pinched or kinked; or to rub against sharp surfaces.
- Carefully position hose to prevent abrasion.
- Use tie straps or clamps to secure hose in position.

Remove oil hose plug from oil supply hose. Store plug on fuel supply hose under engine cover.

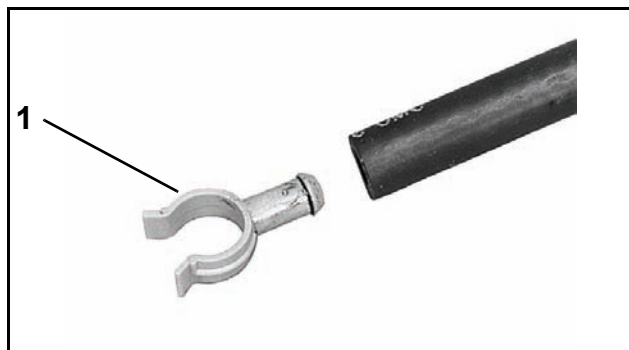

1. Plug

44710

## Oil Tank Sending Unit Harness Routing

Oil tank sending unit harness installation requirements:

- Route harness from oil tank to engine.
- Route through lower engine cover grommet to 2-wire connector (tan and black wires) on engine.
- Carefully position harness in grommet and route alongside main harness.
- Use tie straps to secure harness in position.
- Apply *Electrical Grease* to seal and push connectors together until latched.

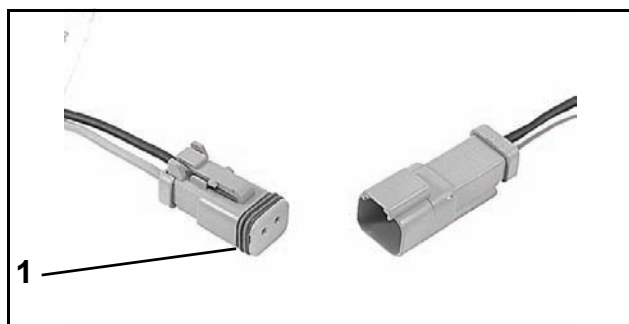

1. Seal

39971

**IMPORTANT:** Remove existing connector and pins and install appropriate connectors to connect oil tank harness to wiring on older outboards.

## Low Oil Warning (SystemCheck instruments only)

**IMPORTANT:** Leave oil tank empty until low oil warning has been tested.

Turn key switch to ON. *SystemCheck* gauge should initiate a test mode, momentarily sound the warning horn, and illuminate all four indicator lights. The “LOW OIL” light should remain illuminated.

Next fill the oil tank with oil and install the oil fill cap. The “LOW OIL” light should turn off.

## Oil Supply Priming

### All Models

Insert the end of the oil supply hose (from the oil tank) into a suitable container. Squeeze the oil primer bulb to flow oil from the oil tank.

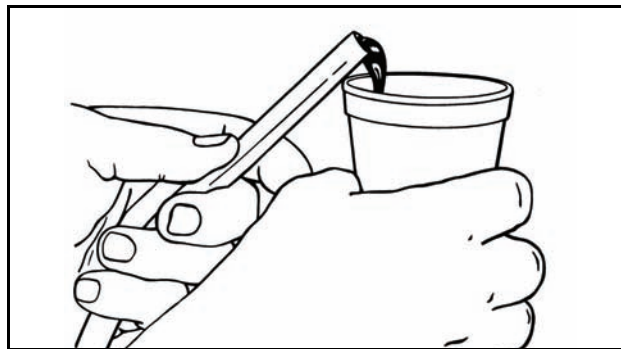

DR4422

Once oil flow is observed, connect the oil tank hose to the outboard's oil supply hose fitting and secure with stepless clamp.

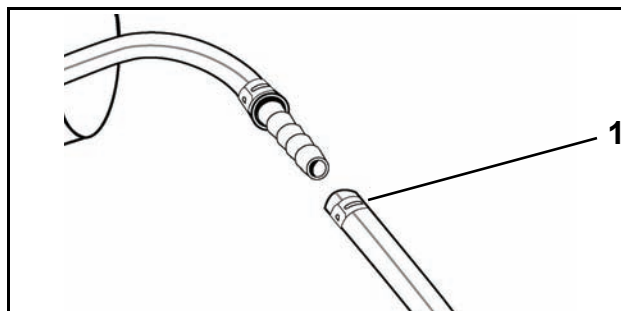

1. Clamp

000066

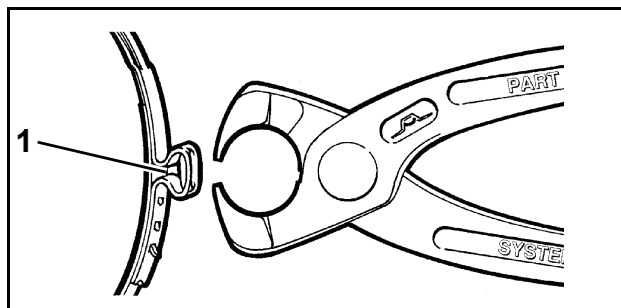

1. Clamp

000092

## Evinrude E-TEC Models

Evinrude E-TEC outboards (75 HP and larger) use a single oil supply hose connected between the outboard and the boat-mounted oil tank.

Follow these steps for initial outboard set-up:

- Squeeze oil primer bulb to flow oil from the hose connection, through the filter, to the oil pump. Visually inspect filter to ensure all air has been purged.
- Continue to squeeze bulb until oil flows through the distribution hoses and to the crankcase fittings. All air must be eliminated from hoses.
- Use *Evinrude Diagnostics* software to confirm oil programming setting (oil type) and to prime oil system. Start outboard and use prime oil function for a minimum of 90 seconds.

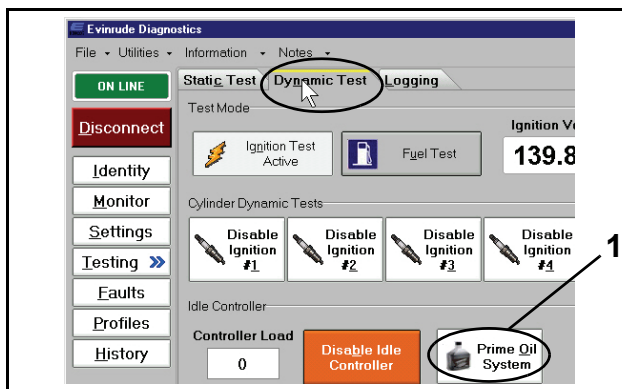

Evinrude Diagnostics, Dynamic Test screen  
1. Prime Oil

005137

## Direct Injection Models (Models using oil return hose)

Remove protective cap from oil tank return fitting and keep with owners kit. Install oil return hose (5/16 in.) and secure with tie strap.

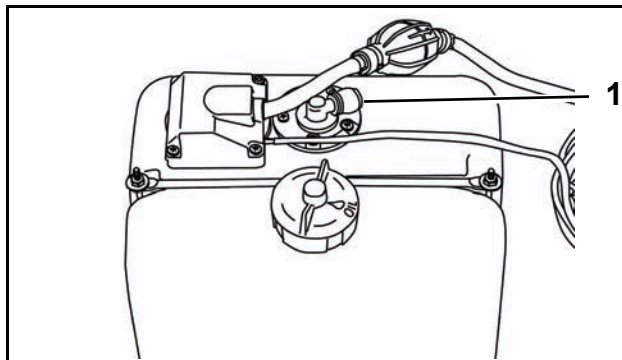

1. Cap

DRC7418A

Oil return hose installation requirements:

- Route hose from oil tank to engine.
- DO NOT allow hose to be pinched or kinked; or to rub against sharp surfaces.
- Carefully position hose(s) to prevent abrasion.

- Use tie straps or clamps to secure hose in position.

Insert oil return fitting (at engine) into a suitable container. Squeeze the oil primer bulb to flow oil from the fitting.

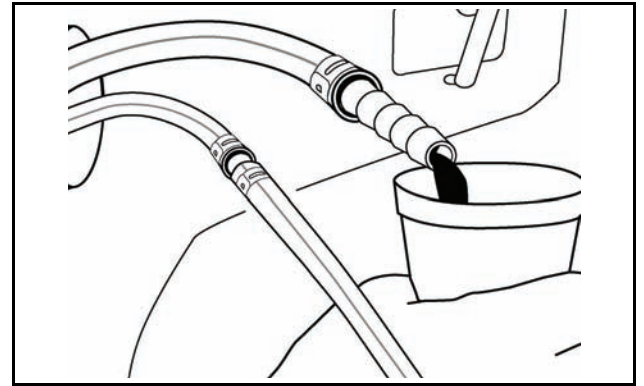

000067

Once oil flow is observed, connect the oil return hose from tank to the outboard's oil return fitting at engine and secure with stepless clamp.

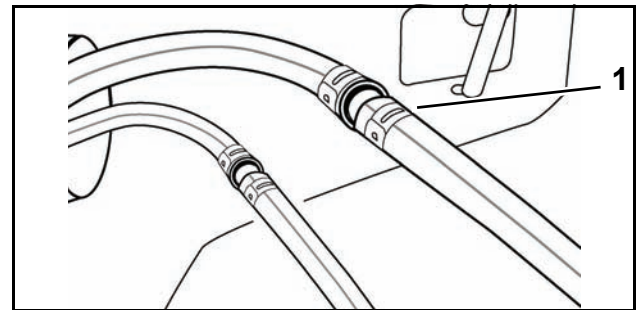

1. Clamp

000068

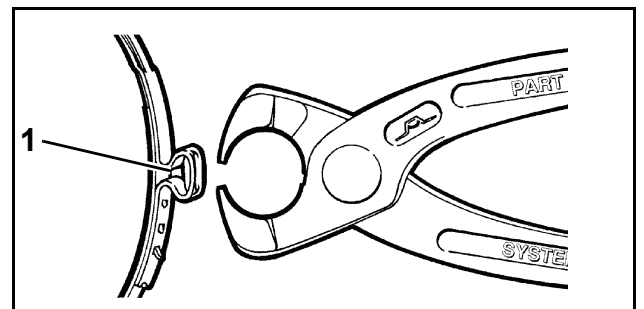

1. Clamp

000092

## Carbureted Models

**IMPORTANT:** Connect pre-mixed oil and fuel supply (50:1) to outboard. Outboard should be equipped with *SystemCheck* gauge.

Start outboard and observe for "NO OIL" warning.

After "NO OIL" warning activates, squeeze oil primer bulb to prime oil system. Warning should stop as oil supply reaches OMS pump.

## Oil Tank Profiles

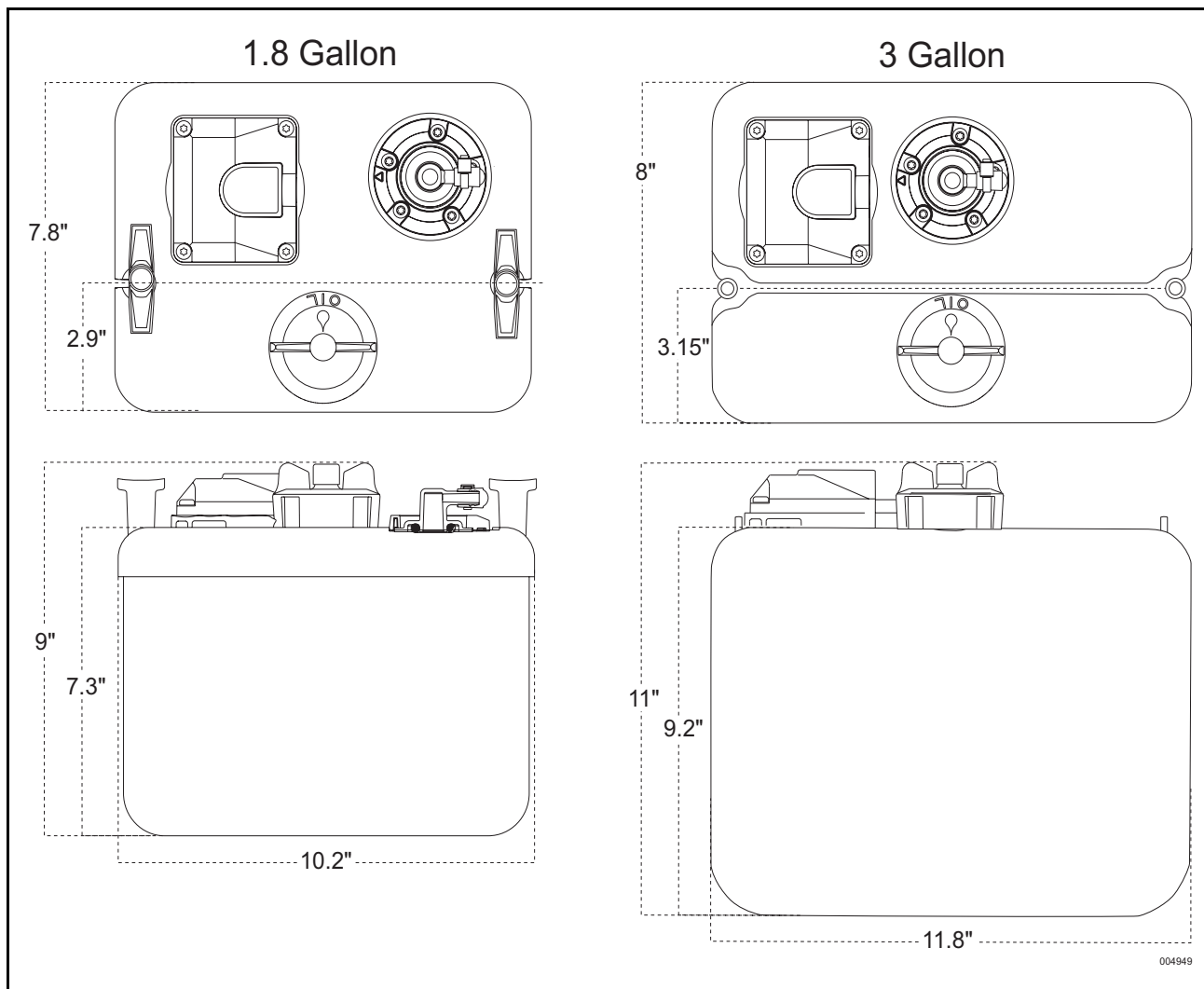

### Remote Oil Fill Kit (Optional)

The remote oil fill kit (P/N 176461) provides a deck-mounted fill tube, cap, and a tank-mounted tube and nut to replace the original oil tank cap assembly.

#### Installation Recommendations

- Select a location on the deck of the boat that is above the oil tank fill cap.
- Select a deck location which allows the required length of 1½ in. I.D. fill hose to route as directly and as vertically as possible.
- Avoid inappropriate hose routings that could distort the fill tube or tank tube.
- Refer to installation instructions provided with remote oil fill kit.

***A slanted area of the deck will allow water to drain away from the fill and is best suited for the installation.***

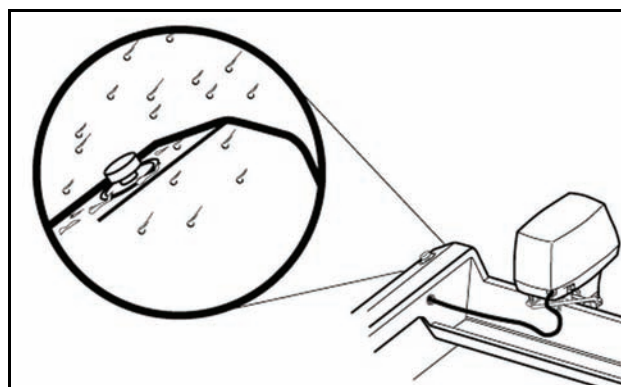

DRC8123

### Additional Items Required

- 1½ in. I.D. fill hose cut to required length. Fill hose (P/N 123956) is available in 25 ft. (7.6 m) lengths.
- Two corrosion resistant 2 in. (50 mm) hose clamps.