



ULTRAFLEX S.p.a.
 Via Crose, 2
 16015 CASELLA (GE) - ITALY
 Marketing Department
 Via Milite Ignoto, 8a
 16012 BUSALLA (GE) - ITALY
 Tel. +39 010 - 9620300
 Fax +39 010 - 9620333
 www.ultraflexgroup.it
 ut@ultraflexgroup.it



B47 - B49

INSTALLATION INSTRUCTIONS

WARNING: THE FOLLOWING INSTRUCTIONS CONTAIN IMPORTANT SAFETY INFORMATION AND MUST BE FORWARDED TO THE BOAT OWNER.

The control unit is designed to mount on the right or left side of the boat.

IMPORTANT SAFETY NOTICE:

- Please read these instructions carefully before installation.
- Improper usage or incorrect assembly can result in loss of engine control with subsequent damages to things and/or injury to persons.
- The Manufacturer does not accept responsibilities for the installations where non-original items are used.
- It is recommended to perform the control system rigging with the boat floating and the engine running.

B47 - B49 control units, using the respective connection kits, can utilize the following Ultraflex cables:

- C5 (no connection kit required)
- C14 (K23 connection kit required)
- C4 - C10 (K24 connection kit required)
- C2 - C7 - C8 (K25 connection kit required)

FRICITION INSTALLATION (Fig. 1)

Fit friction springs 4 and friction caps 5 into the provided holders. Perform this procedure on both half-cases.

INSTALLATION WITHOUT CONNECTION KIT (FIG. 2) for type C5 cables

Attach the type C5 cables to throttle and shift levers using the pivot pins 8 and circlips 6 in one of two positions B or B' depending on the engine model.

Secure each lever to the corresponding half-case with the screws 7, the plastic washers 10 and the brass washers 11 (Refer to exploded view).

INSTALLATION WITH CONNECTION KIT K23 (FIG. 3) for type C14 cables

Insert the adapter A into the holder provided on the half-case.

Attach the type C14 cable to sliding block P using circlip X.

Attach the pivot pin 8 to the control lever using circlip 6 in one of two positions B or B'.

Connect the sliding block mounted on the cable to pivot pin 8.

Insert control lever onto hub provided in the half-case and attach with the screw 7, the plastic washer 10 and the brass washer 11 (Refer to exploded view).

Perform this procedure on both half-cases.

NOTE: For this installation the circlip Z is not used.

LEFT-SIDE INSTALLATION

RIGHT-SIDE INSTALLATION

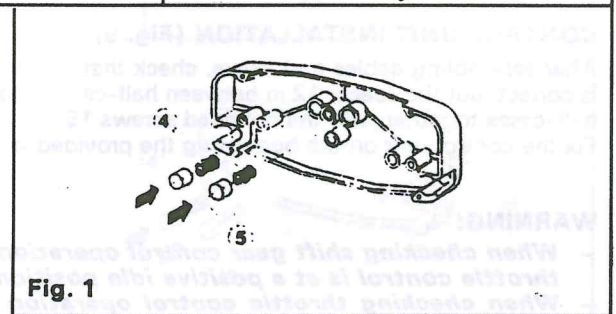
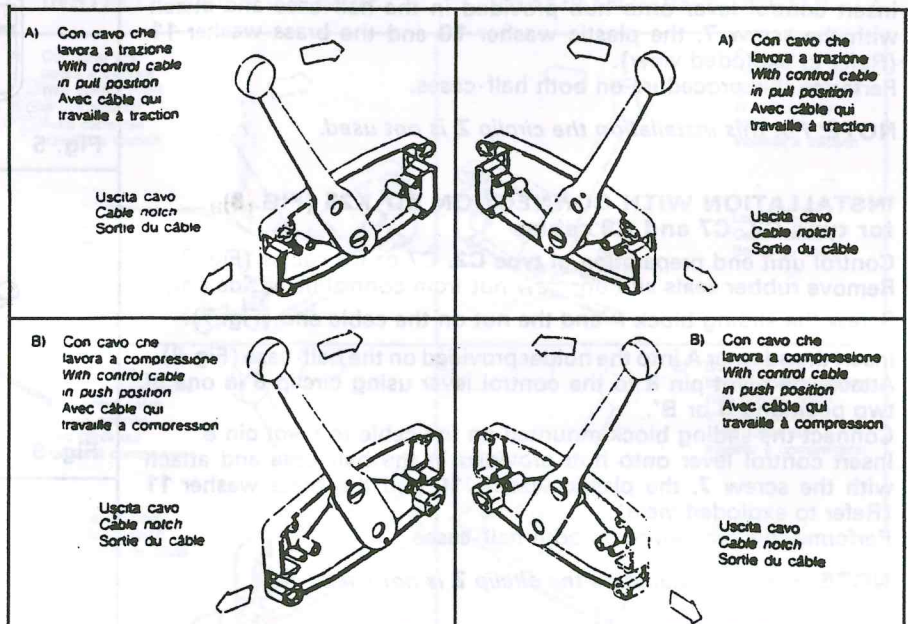

Fig. 1

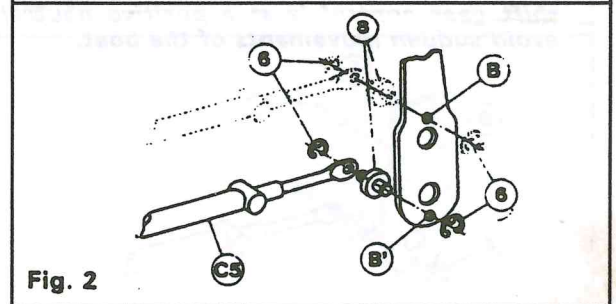

Fig. 2

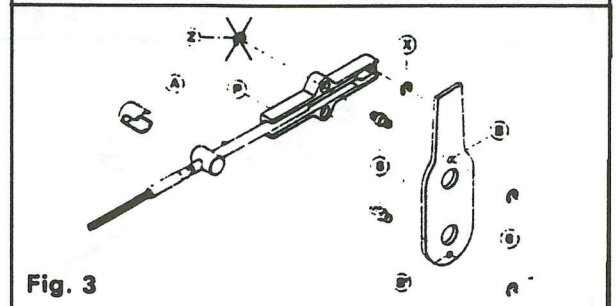

Fig. 3

INSTALLATION WITH CONNECTION KIT K24 (FIG. 6)
for type C4 and C10 cables

Engine end preparation of type C4 or C10 cables (Fig. 4):
Mount sleeves C on the throttle and shift cables moving adjustment nut R all the way back. Fix the inner core of the cable to sleeve C with screws V.

Control unit end preparation of the cables (Fig. 5)
After positioning the cable at "close travel" on the engine end, insert the other end of the cable in the sliding block P and place in the half-case as shown in the illustration. Fix the cable to the sliding block using the screws V'.

Cut cable inner core not required.

Insert the adapter A into the holder provided on the half-case (Fig. 6). Attach the pivot pin 8 to the control lever using circlip 6 in one of two positions B or B'.

Connect the sliding block mounted on the cable to pivot pin 8. Insert control lever onto hub provided in the half-case and attach with the screw 7, the plastic washer 10 and the brass washer 11 (Refer to exploded view).

Perform this procedure on both half-cases.

NOTE: For this installation the circlip Z is not used.

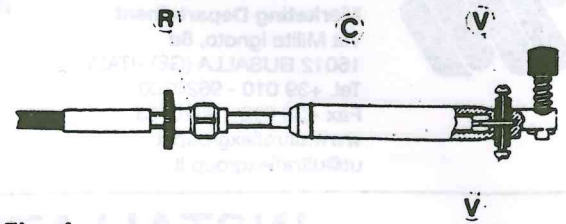

Fig. 4

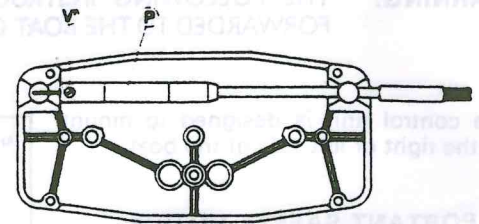

Fig. 5

INSTALLATION WITH CONNECTION KIT K25 (FIG. 8)
for type C2, C7 and C8 cables

Control unit end preparation of type C2, C7 or C8 cables (Fig. 7):
Remove rubber seals and unscrew nut from control head side only. Screw the sliding block P and the nut on the cable end (Fig. 7).

Insert the adapter A into the holder provided on the half-case (Fig. 8). Attach the pivot pin 8 to the control lever using circlip 6 in one of two positions B or B'.

Connect the sliding block mounted on the cable to pivot pin 8. Insert control lever onto hub provided in the half-case and attach with the screw 7, the plastic washer 10 and the brass washer 11 (Refer to exploded view).

Perform this procedure on both half-cases.

NOTE: For this installation the circlip Z is not used.

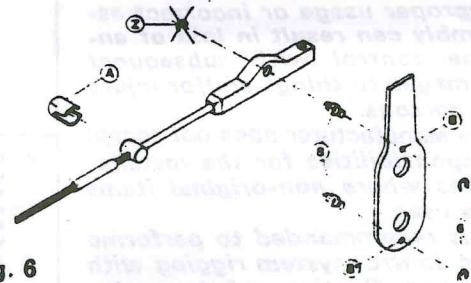

Fig. 6

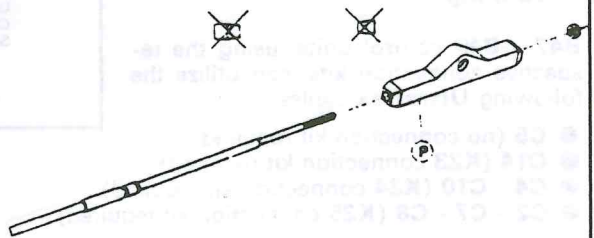

Fig. 7

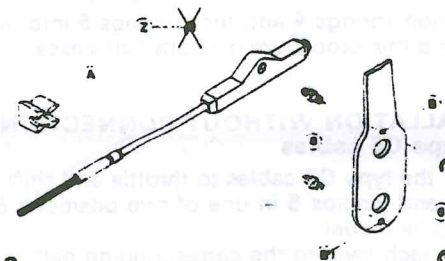

Fig. 8

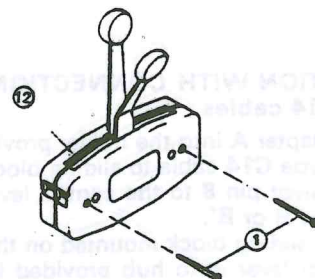

Fig. 9

CONTROL UNIT INSTALLATION (Fig. 9)

After assembling cables and levers, check that the control direction is correct, put the spacer 12 in between half-cases, then join the two half-cases together with the provided screws 15. Fix the control unit on the boat using the provided wood screws 1.

WARNING:

- When checking shift gear control operation be sure the throttle control is at a positive idle position.
- When checking throttle control operation be sure the shift gear control is at a positive neutral position to avoid sudden movements of the boat.

ELENCO DELLE PARTI

PARTS LIST

LISTE DES PIÈCES

| PARTE ITEM PIÈCE | DESCRIZIONE | DESCRIPTION | DESCRIPTION | Q.TA Q.TY Q.TÉ |
|------------------------|-------------------------|-----------------|----------------------|----------------------|
| 1 | Vite (6x70) | Screw (6x70) | Vis (6x70) | 2 |
| 2 | Targhetta | Placard | Plaque | 1 |
| 3 | Semiscatola | Half-case | Semi-boîtier | 1 |
| 4 | Molla | Spring | Ressort | 4 |
| 5 | Cilindretto di frizione | Friction cap | Cilindre de friction | 4 |
| 6 | Anello D5 | Circlip D5 | Anneau D5 | 4 |
| 7 | Vite (M6x12) | Screw (M6x12) | Vis (M6x12) | 2 |
| 8 | Perno | Pivot pin | Pivot | 2 |
| 9 | Leva nera | Lever, black | Levier noir | 1 |
| 10 | Rondella, plastica | Washer, plastic | Rondelle, plastique | 2 |
| 11 | Rondella, ottone | Washer, brass | Rondelle, laiton | 2 |
| 12 | Diaframma | Spacer | Diaphragme | 1 |
| 13 | Leva rossa | Lever, red | Levier rouge | 1 |
| 14 | Semiscatola | Half-case | Semi-boîtier | 1 |
| 15 | Vite (M6x35) | Screw (M6x35) | Vis (M6x35) | 2 |
| | Vite (4x20) | Screw (4x20) | Vis (4x20) | 3 |
| | Fermaguaina | Casing fastener | Arrête-gaine | 3 |

