

MEMBER
ABYC
Setting Standards for Safer Boating

1.3

ONE POINT THREE
ISO 9001

BAYSTAR™

CAPILANO™

SEASTAR™

INSTALLATION INSTRUCTIONS

AND OWNER'S MANUAL

www.seastarsolutions.com

Now with
adjustable O-ring
hose fittings



SEASTAR™

Hydraulic Steering for Outboard
Powered Vessels

Front Mount Pivot Cylinder



SEASTAR
SOLUTIONS®

*Before you do it your way,
please try it our way*

To the Installer and End User (Owner)

Thank you for choosing SeaStar Steering Systems by SeaStar Solutions. This Installation and Owner's Manual contains all the information that you and others will require for the safe installation and use of your steering system and MUST remain on board the boat. Throughout this manual, information for the safe installation and operation of the steering system will be distinguished in one of the following ways;

WARNING

Hazards or unsafe practices which could result in severe personal injury or death.

Failure to adhere to a warning may lead to loss of steering control. Loss of steering control may result in unpredictable boat behavior, leading to ejection from boat causing property damage, personal injury and/or death.

CAUTION

Hazards or unsafe practices which could result in minor injury or product or property damage.

NOTICE

Important information in regards to installation, use and maintenance of the steering components.

NOTICE

Marine Canada Acquisition Inc. DBA SEASTAR SOLUTIONS is referred to as SeaStar Solutions throughout this publication.

These safety alerts alone cannot eliminate all of the hazards that may be present while on the water. SeaStar Solutions recommends that all users of the steering system take an accredited 'boating safety course', follow safe boating practices and are made aware of the environment that they will be in.

SAFETY INFORMATION

WARNING

The safety information provided below is intended to inform you of the dangers that may be present before, during and after the installation. It is critical that you read and understand ALL the points noted.

The safe operation of the steering system is dependant upon proper installation and maintenance, common sense, safe judgment and the knowledge/expertise of the operator. Every installer/user of the steering system should know the following requirements 'before' installing/using the steering system.

If you have any questions regarding any of these warnings, contact SeaStar Solutions.

To reduce risk of severe injury or death. Always wear a Coast Guard Approved personal flotation device (PFD) and use an engine shut-off cord (lanyard).

Before installation

1. Read and understand the Installation and Owner's Manuals provided with your steering components.
2. Ensure that all components required to complete the installation are on hand (including hoses, fittings, oil and the proper tools required for the installation).
3. SeaStar components are highly engineered and safety tested to ensure system integrity, DO NOT substitute any component with non-SeaStar components as this may compromise system performance/reliability.

Installation

CAUTION

-3 steering cylinders are fitted with ORB hose fittings. DO NOT use NPT fittings. irreparable damage to cylinder WILL occur.

1. Install components as directed in all Installation Manuals (including helm pumps, hoses and fitting kits).
2. DO NOT modify or substitute any component in any way without written consent from SeaStar Solutions.
3. Comply with all system ratings/regulations (boat/engine, U.S.C.G.).
 - Cylinder MUST be compatible with engine(s) installed.
 - Cylinder MUST be rated for use on the engine(s) installed.
4. Confirm that there is no interference between the steering cylinder(s), tiebars and the transom, splashwell, outboard engine or jackplate or any combination of these parts by performing the following steps;
 - a) With engine fully tilted DOWN, turn steering wheel from hard over to hard over and confirm that no interference occurs.
 - if using a hydraulic jack plate the above must also be performed at all the positions of the jack plate.
 - b) Repeat step 4a) with engines tilted UP.
 - c) Perform step 4a) with each engine in DOWN/UP positions confirming that independent TRIM/TILT can be done without any interference.
5. Confirm that the steering cylinder can be fully stroked in both directions as well as full tilt and trim without stretching, chafing, rubbing and/or kinking of the hydraulic hoses.
6. Confirm that extruded nylon tubing has NOT been substituted for SeaStar Steering Hose.
7. DO NOT use a wire coil type trim switch with a hydraulic steering system as the wire can wind up tight around the steering wheel shaft and prevent further steering.
8. Conduct Oil Level and System Check as outlined on page 40 of this manual.

Safety Information Continued

WARNING

The safety information provided below is intended to inform you of the dangers that may be present before, during and after use. It is critical that you read and understand ALL the points noted.

Prior to every use

1. Check Fluid level in highest helm pump (see page 35 for proper fluid level setting).
2. Verify immediate steering response when turning steering wheel(s). (Ensure engine turns when steering wheel is turned.)
3. Visually inspect all steering hoses and fittings for wear, kinking and/or leaks.
4. Check for binding, loose, worn or leaking steering components.

DO NOT OPERATE BOAT IF ANY COMPONENT IS NOT IN PROPER WORKING CONDITION.

During use

1. WEAR A COAST GUARD-APPROVED PERSONAL FLOTATION DEVICE (PFD).
2. ATTACH ENGINE SHUT-OFF CORD (LANYARD) TO YOUR PFD.
3. Never allow anyone not familiar with the operation of the steering system operate the boat at any time.
4. Know and adhere to the operator restrictions for your area including;
 - Federal Laws/Regulations,
 - State Laws/Regulations and
 - Municipal Laws/Regulations.

DO NOT OPERATE BOAT IF ANY COMPONENT IS NOT IN PROPER WORKING CONDITION.

After use

1. Rinse off steering system thoroughly using 'fresh, clean water only'.
 - Cleaning fluids containing ammonia, acids or any other corrosive ingredients **MUST NOT** be used for cleaning any part of the hydraulic steering system.

Maintenance

1. Maintain steering system at a minimum of twice per year.
 - See Maintenance, on page 41 of this manual.

Keep our waters clean for all current and future users. Dispose of ALL fluids in accordance with your local regulations.

INTRODUCTION

Before proceeding with the installation, read these instructions thoroughly. SeaStar Solutions cannot accept responsibility for installations where instructions have not been followed, where substitute parts have been used, or where modifications have been made to our products.

NOTICE

Due to a small amount of internal hydraulic slip, a “master spoke” or “centered” steering wheel cannot be maintained with a hydraulic steering system. For best results, use an equal distance spoke steering wheel. SeaStar Pro Helm Pumps are not 100% locking and therefore, a small amount of hydraulic drift is normal.

⚠ WARNING

DO NOT use a wire coil type trim switch with a hydraulic steering system. Wire coil can wind up tight around the steering wheel shaft and prevent further steering!

Pro Trim offers fingertip trim or jackplate control with a column-mounted switch, enabling you to keep both hands on the steering wheel and concentrate on your driving. Pro Trim PT1000 controls trim or jackplate only. Pro Trim Dual PT2000 controls both functions.

Index

Introduction	1
Minimum Splashwell Dimensions.....	2
Front Mount Cylinder.....	2
Dimensional Specifications.....	2
300HP + Installation Recommendations.....	3
Tools.....	4
System Overview	
Step 1 System Installation	5
Step 2 Filling & Purging Procedure	5
Step 3 Oil Level and System Check	5
Step 4 Routine Maintenance	5
Hydraulic Hose Installation	7
Installation Instructions	
Front Mount & Tournament Type Cylinders.....	9
H05090 Spacer Kit.....	10
Ground Strap Installation	11
Tie Bar Installation.....	12
Positional O-Ring Horizontal and Vertical Tee Fitting Installation/Realignment	13
SeaStar Pro Cylinder.....	14
Single Engine Applications.....	15
Twin Engine Applications	23
Filling and Purging	35
Hydraulic Oil Requirements.....	35
Single Station Single Cylinder	37
Twin Station One Cylinder.....	39
Single Station Twin Cylinder.....	39
Twin Station Twin Cylinder	39
Oil Level and System Check	40
Routine Maintenance	41
Troubleshooting Guide	42
Technical Information	44
Seal/Replacement Parts	45
Statement of Limited Warranty	46
Return Goods Procedure	46

Before attempting installation, ensure that the splashwell of your boat has the following minimum dimensions.

Minimum Splashwell Dimensions

# OF ENGINES	A	B	C	MIN. ENGINE CENTER DISTANCE
1	22" (559mm)	6" (152mm)	5" (127mm)	N/A
2	44" (1118mm)	6" (152mm)	5" (127mm)	26" (660mm)

NOTE:

- a) Dimensional restrictions also apply to external motor mount brackets.
- b) Maximum engine center distance for twin engine applications is 36" (914mm) using the standard tie bar. Dimension 'A' would have to be increased proportional to the tie bar length.

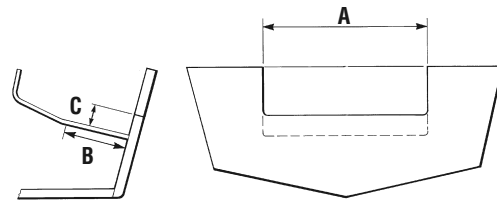

Front Mount Cylinder

Part # HC5345-3, HC5347-3, HC5348-3, HC5358-3, HC5375-3, HC5385-3, HC5445-3.

Splashwells of less than 30" in overall width may require engine removal in order to install the support rod (Part # 730229).

Dimensional Specifications

Dimensions shown in Figure 1 are the same for all part numbers. Pivot plate dimensions vary between part numbers.

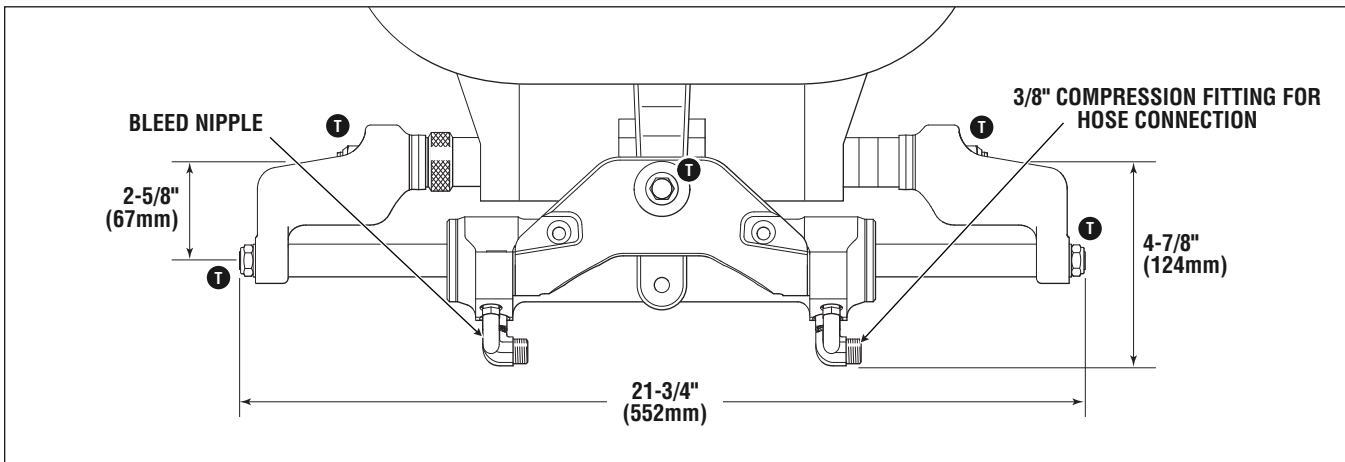

Figure 1.

T Ensure correct Torque at these points.

CAUTION

-3 steering cylinders are fitted with ORB hose fittings. **DO NOT** use NPT fittings. irreparable damage to cylinder WILL occur.

300HP + Installation Recommendations

With the introduction of heavier, higher horsepower engines producing more torque, SeaStar Solutions has updated its recommendations across various applications (single and multiple engines, different hull types, etc.) Please read carefully to ensure that your current steering system provides the best comfort versus performance available.

NOTICE

For information on SeaStar Tournament Cylinders HC6845, please refer to Book #48 included with the steering cylinder or, www.seastarsolutions.com

ENGINE	SEASTAR FRONT MOUNT <i>(Normal Use)</i>	SEASTAR TOURNAMENT SERIES <i>(Aggressive Use – See Note 1)</i>	HYNAUTIC K-6 <i>(Normal Use ONLY)</i>
SINGLE ENGINE	SINGLE CYLINDER 350 HP Max 75 MPH Max HC53xx Cylinder <i>(See Note 2)</i>	SINGLE CYLINDER 350 HP Max HC63xx Pro Cylinder <i>See Notes 2 & 3)</i> or HC6845S Tournament Cylinder	SINGLE CYLINDER 300 HP Max 55 MPH Max
DUAL ENGINES NON COUNTER ROTATING	SINGLE CYLINDER 450 HP Max 55 MPH Max HC53xx Cylinder HO60xx Tie Bar	SINGLE CYLINDER Tournament Cylinder HC6845 Cylinder HA6802 Hardware Kit HO682x Tiebar Kit	SINGLE CYLINDER 400 HP Max 55 MPH Max
	DUAL CYLINDERS 600 HP Max 55 MPH Max HC53xx Cylinders HO60xx Tie Bar	DUAL CYLINDERS Tournament Cylinders HC6845 Cylinders HA6804 Hardware Kit HO682x Tiebar Kit	DUAL CYLINDERS 500 HP Max 55 MPH Max
DUAL ENGINE COUNTER ROTATING	SINGLE CYLINDER 600 HP Max 55 MPH Max HC53xx Cylinder HO60xx Tie Bar	SINGLE CYLINDER Tournament Cylinder HC6845 Cylinder HA6802 Hardware Kit HO682x Tiebar Kit	SINGLE CYLINDER 500 HP Max 55 MPH Max
	DUAL CYLINDERS 600 HP Max 55 MPH Max HC53xx Cylinders HO60XX Tie Bar	DUAL CYLINDERS Tournament Cylinders HC6845 Cylinders HA6804 Hardware Kit HO682x Tiebar	DUAL CYLINDERS 500 HP Max 55 MPH Max
TRIPLE ENGINES ONE WITH COUNTER ROTATING	DUAL CYLINDERS 900 HP Max 55 MPH Max HC53xx Cylinders HO60xx Tie Bar	DUAL CYLINDERS Tournament Cylinders HC6845 Cylinders HA6806 Hardware Kit HO682x Tiebars	NOT RECOMMENDED
	TRIPLE CYLINDERS 900 HP Max 55 MPH Max HC53xx Cylinders HO60xx Tie Bar	DUAL CYLINDERS Tournament Cylinders HC6845 Cylinders HA6806 Hardware Kit HO682x Tiebars	
QUAD ENGINE APPLICATIONS	Contact SeaStar Technical Support		

- 1 SeaStar Solutions has specific steering equipment for boats that are driven aggressively, used in severe conditions or with more than 300 HP per engine.
- 2 Tournament cylinders **MUST** be plumbed in parallel **ONLY**, so series connections. Only exception is if cylinders are utilizing a liquid tiebar

- 3 HC63xx PRO Cylinders are designed for all those critical high speed, single outboard engine boats, such as Bass, Flats combo Race/Ski and other performance orientated boats capable of speeds in excess of 65 mph. For optimal performance, the use of SeaStar PRO Kevlar Steering Hoses is recommended.

Tools

You will need the following tools to complete your installation.

- 5/16" (8mm) dia. Drill Bit
- 7/16", 1/2", 9/16", 5/8" and 3/4" Open End type Wrench/Spanner
- 15/16" Socket for SeaStar helms wheel shaft nut
- 1" Hole Saw for Rear Mount helms
- 3" Hole Saw for Front Mount, Sport and Sport Plus helms
- 4" Hole Saw for Classic Tilt helms

Additional tools needed**20° Mount Wedge**

- Key Hole or Sabre Saw
- 5/16" (8mm) dia. Drill Bit
- 1/2" Wrench/Spanner, Box or Open End type
- 7/16" Socket and Drive

Cylinder, Outboard Front Mount Type

- 5/8", 3/4", 1/2", 9/16" Wrench/Spanner, Box or Open End type, 2 required.
- 5/32" Allen Key/Wrench

SYSTEM OVERVIEW

HELM

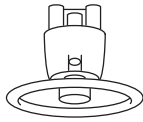

STEP 1 System Installation

- Install SeaStar helm pump onto dash using the installation instructions provided with your helm pump. To ease installation it is good practice to install hose fittings into helm pump prior to installing helm onto dash.

! WARNING

CYLINDER

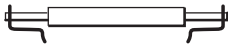

Ensure that you read and understand **ALL** cautions, notices and warnings that are noted in your helm pump installation instructions.

- Install SeaStar Steering Cylinder as outlined on page 9 of this manual.
- Install Ground Strap as outlined on page 11 of this manual.
- Install steering hoses as outlined on page 7 of this manual.

! CAUTION

-3 steering cylinders are fitted with **ORB** hose fittings. **DO NOT** use **NPT** fittings. Irreparable damage to cylinder **WILL** occur.

STEP 2 Filling and Purging Procedure

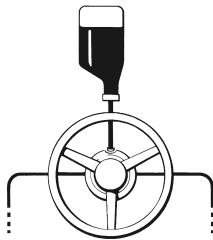

- Refer to fill and purge procedures as outlined on page 35 of this manual.

NOTE: *Power Assist and Catamaran users please use bleeding details included with your Power Assist or, Liquid Tiebar Installation Instructions.*

STEP 3 Oil Level and System Check

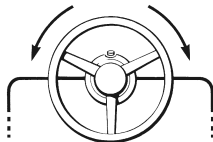

- Refer to page 40 of this manual for setting oil level in helm pump and performing the “system pressure test” to ensure steering system is ready for use.

! WARNING

Oil level and System check is critical to the safe operation of your boat, failure to follow this important step may lead to loss of steering control resulting in property damage, personal injury and/or death.

STEP 4 Routine Maintenance

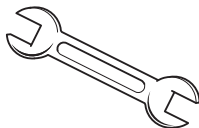

- Refer to page 41 of this manual to become familiar with the routine maintenance that **MUST** be carried out in the intervals noted.

Note: *This page left blank intentionally.*

HYDRAULIC HOSE INSTALLATION

Steering hoses and how they are installed are critical to the safe operation of your steering system. SeaStar Solutions recommends the use of SeaStar Steering hoses ONLY. Use of any other hose may drastically reduce system performance and safety.

WARNING

DO NOT cut SeaStar steering hoses, cutting these hoses will render them useless.

Before continuing on with the installation of your steering hoses, please ensure that you read and understand the important points shown below;

- DO NOT install any pipe sealant onto the "hose" side of a fitting.
- DO NOT remove protective end covers until the hoses have been routed and are ready to be connected to the helm pump, hose fitting or steering cylinder(s).
- Before, during and after installation the hoses MUST be protected from chaffing, rubbing, and contact or interference with assembly screws or sharp edges of any type.
- DO NOT install hoses in an area where they will be exposed to high heat, such as engine manifolds, engine compartments or highly corrosive areas such as battery fumes or electrical connections.
- If possible, route hoses through a protective PVC cover.
- Secure hoses in minimum 2' increments.
- DO NOT bend hoses tighter than a 3-1/2" (89mm) radius.
- Provide sufficient hose lengths to allow for cylinder movement throughout the turning arc and UP/DOWN trim/tilt settings of the engine(s).
- DO NOT allow hoses to hang free in an area where they could become a safety hazard.
- DO NOT use extruded nylon tubing for plumbing an outboard system. Extruded nylon tubing can only be used for return/compensating lines between power assist and/or autopilot pumps and the helm pump.
- Where possible, route hoses in an area where they can be easily inspected for wear on a regular basis.

CAUTION

-3 steering cylinders are fitted with ORB hose fittings. DO NOT use NPT fittings. irreparable damage to cylinder WILL occur.

WARNING

Continuous kinking, rubbing, chafing or twisting of a steering hose may eventually weaken the hose(s) to a point where it could rupture. Rupture of a hose will lead to loss of steering control.

STEP 1 Set Up

- See Figure 3 on the next page to locate your plumbing diagram.
- Mark each end of the hose to ensure proper connection.

NOTICE

Hoses are crossed from the helm pump(s) to the steering cylinder(s). Port side helm connection will be installed onto the starboard fitting on the cylinder, and the Starboard side helm connection will be installed onto the port side fitting on the cylinder.

STEP 2 Routing

Throughout the hose installation, ensure the protective caps remain installed onto the end of the hoses. Doing so will prevent contamination from entering the system.

- Route steering hoses so that the hose bend restrictor will be located at the steering cylinder(s).
- Route steering hoses so that they have a gradual rise from the steering cylinder(s) to the helm pump.

HYDRAULIC HOSE

INSTALLATION

- If routing hoses through a blind area, ensure that the area is free and clear of any sharp edge, screw or any other object that may damage the hose.
- Secure hoses every 2'.

⚠ WARNING

Substituting brass fittings into the steering cylinder will result in galvanic corrosion and irreparable damage to the cylinder as well as affect system integrity.

1. Minimum bend radius 3-1/2" (89mm).
2. If orientation is required, see page 13 for ORB Hose fitting installation/realignment.
3. Hoses should be secured to the control cable harness if they enter the splashwell through the boot.

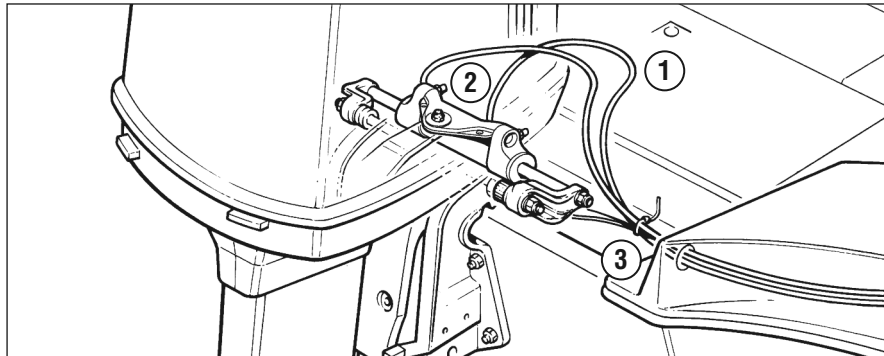

Figure 2.

STEP 3 Hose to fitting installation

- Remove protective covers.
- Install hose end fitting onto intended fitting, tighten hand tight.
- While holding the receiving fitting with a wrench, tighten hose fitting to 15ft-lb.

⚠ WARNING

When installed, confirm that the hoses are not being pulled or kinked over by pushing the engine(s) back and fourth. Hoses must NOT be pulled on at any time.

NOTICE

Power Assist and Catamaran Systems please refer to the installation instructions included with the power assist and/or liquid tiebar valve.

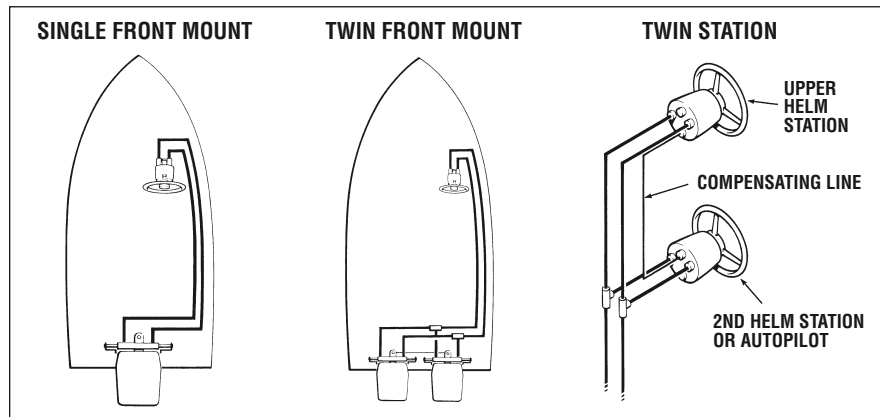

Figure 3.

Hose Inspection

DO NOT operate the vessel if ANY of the following are observed:

- Fitting slippage on hose
- Damaged, cracked, cut or abraded cover (or any reinforcement exposed)
- Hard, stiff, heat cracked, or charred hoses;
- Cracked, damaged, or badly corroded fittings;
- Leaks at fitting, or in hose;
- kinked, crushed, flattened or twisted hose; and
- blistered, soft, degraded, or loose cover.

INSTALLATION INSTRUCTIONS

Front Mount Cylinders

HC5345-3, HC5347-3, HC5348-3, HC5358-3, HC5375-3, HC5385-3, HC5445-3 and HC6345-3.

NOTICE

Installation of PRO and Catamaran cylinders are similar to that of the front mount cylinders. Notes will be made when differences occur. For Tournament Cylinders please refer to Installation Book 48 included with your tournament steering cylinder.

On the following pages of this instruction booklet you will find the assembly drawing for your specific application.

NOTICE

Before beginning installation make sure that all mounting hardware is included and that the tiller arm and tilt tube bolt holes are clean & free from rust or burrs.

⚠ CAUTION

Engines with rigid engine mounts have been shown to cause premature wear to the pivot cylinder — therefore, please perform a complete inspection of your steering system as outlined in the Maintenance Section at the back of this manual.

Single Engines

NOTICE

Please refer to the table below if using any PRO, Catamaran or Tournament Type Cylinders. Installation will be the same as that shown, any changes will be noted when required.

Cylinder Part #	Install as per Cylinder Part #
HC6345-3	HC5345-3
HC5375-3	HC5345-3
HC5445-3	HC5345-3

⚠ WARNING

Refer to page 44 for the correct torque specifications for your installation. Failure to correctly install your steering cylinder and torque all screws may result in steering failure causing property damage and/or personal injury.

⚠ CAUTION

STEP 1: Using an approved quality marine grease (such as Johnson/Evinrude triple guard, Quicksilver anti-corrosion, Yamaha marine grease or equivalent), liberally lubricate the tilt tube and support rod (Item 9) and slide the support rod through the engine tilt tube.

STEP 2: Lightly grease the tiller bolt (Item 2) & partially screw into appropriate hole in the tiller arm to assure a proper fit. Remove and go to Step 3.

⚠ WARNING If the engine manufacturer has installed caps, plugs and/or screws into the tiller arm, these caps, plugs and/or screws **MUST** be removed prior to continuing on with installation.

STEP 3: Select appropriate insert diagram from page 10 to page 22 to determine proper orientation of the cylinder assembly, the tiller bolt and self locking nut (Items 13, 2 and 1). Grease tiller bolt as indicated and fully thread tiller bolt (Item 2) into the steering arm. While holding the head of the tiller bolt with a wrench, tighten and torque tiller nut (Item 1) as specified in this manual.

⚠ WARNING It is required that the tiller bolt head is held in place with a wrench while the tiller nut is torque to the proper specification, failure to do so may result in loss of steering control causing property damage, personal injury and/or death.

STEP 4: a) Screw the adjusting nut (item 10) all the way onto the tilt tube. b) Place the stainless washers (Item 11) and the plastic spacers (Items 7 & 8) on the support rod.

⚠ CAUTION Refer to your specific application figure for proper orientation of spacers on both sides of the engine tilt tube.

STEP 5: Attach and secure support brackets (Item 12) to the support rod and the cylinder shaft. Tighten using the nuts, bolts and washers (Items 3, 4, 5 & 6) as illustrated in application figures.

STEP 6: Eliminate the free play in the support rod by turning the adjusting nut (Item 10) counter clockwise until snug. Never use a wrench on the adjusting nut. Always hand tighten. Lock the adjusting nut in place by tightening the Hexagon set screw.

If installing a jack plate make sure that there isn't any interference between the jack plate and your steering cylinder. If there is interference, it may occur during full tilt and you should install lift restrictors (Tilt Stop Switch). Some engine manufacturers supply these as standard equipment.

H05090 Spacer Kit For use with ALL SeaStar front mount cylinders.

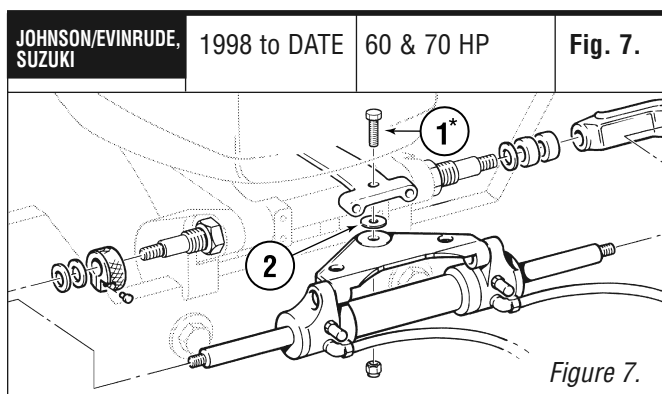
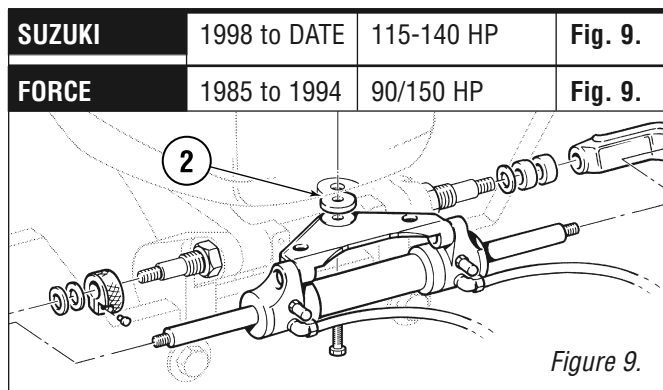
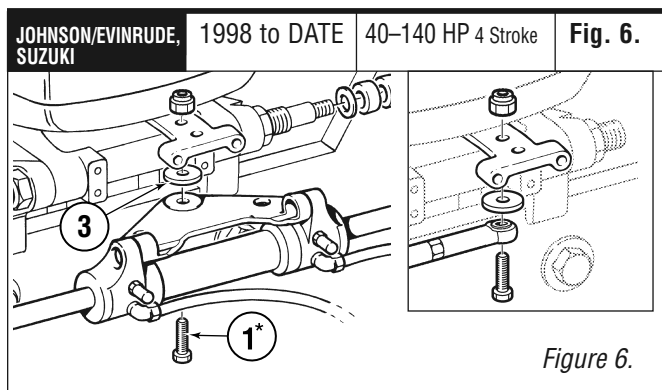
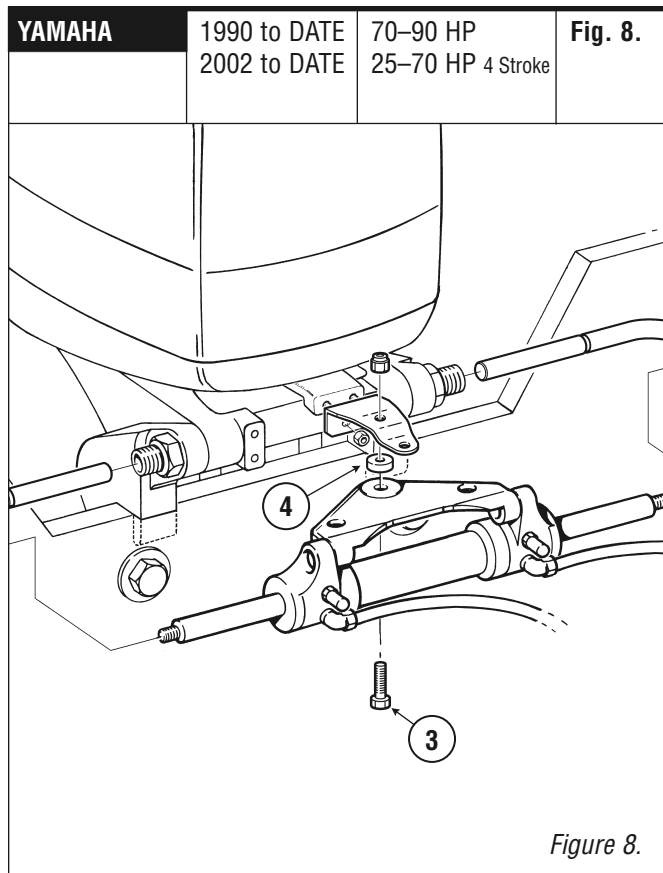
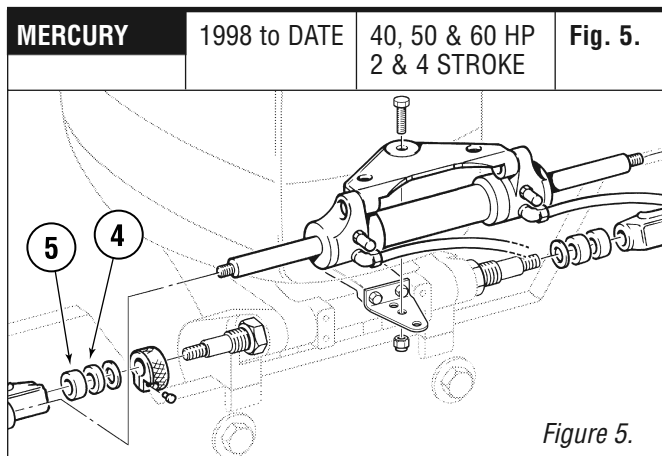
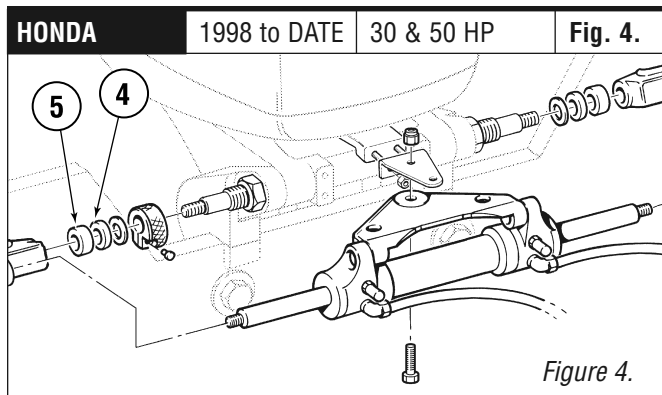

ITEM	PART #	QTY	DESCRIPTION
*1	688726	1	HHCS 3/8" NF x 2-1/4" SS (Tiller Bolt)
2	113600	1	SS Fender Washer
3	773421	1	Aluminum Spacer 1/2"
4	728994-1	1	3/16" Spacer, Yamaha
5	995876	2	Thick Nylon Spacer 3/8"

PLEASE NOTE: Items are only available in Kit# H05090, parts are not sold separately.

* Refer to page 44 for correct torque specifications.

Ground Strap Installation

SeaStar Solutions strongly recommends use of a ground strap on any outboard hydraulic steering cylinder with an exposed shaft (such as SeaStar front mount steering cylinders). This ground strap will provide added protection against corrosion caused by stray current.

Installation Details

- Install ground strap to cylinder as per Figure 10.
- Reinstall cylinder and support rod nuts, torque to the following
 - i) cylinder shaft nut = 33 ft.lb.
 - ii) support rod shaft nut = 45 ft.lb.
- Route ground strap UNDER the tilt tube and attach loose end of strap to the starboard side lower midsection steering bracket bolts using the correct fasteners.
- Ensure there is enough slack in the strap to allow the engine to pivot freely in ALL trim/tilt positions and throughout the entire steering range of the engine.

⚠ CAUTION

Ensure ground strap is routed 'under' the tilt tube. Installation of the strap 'above' the tilt tube may lead to a hang up, or restriction.

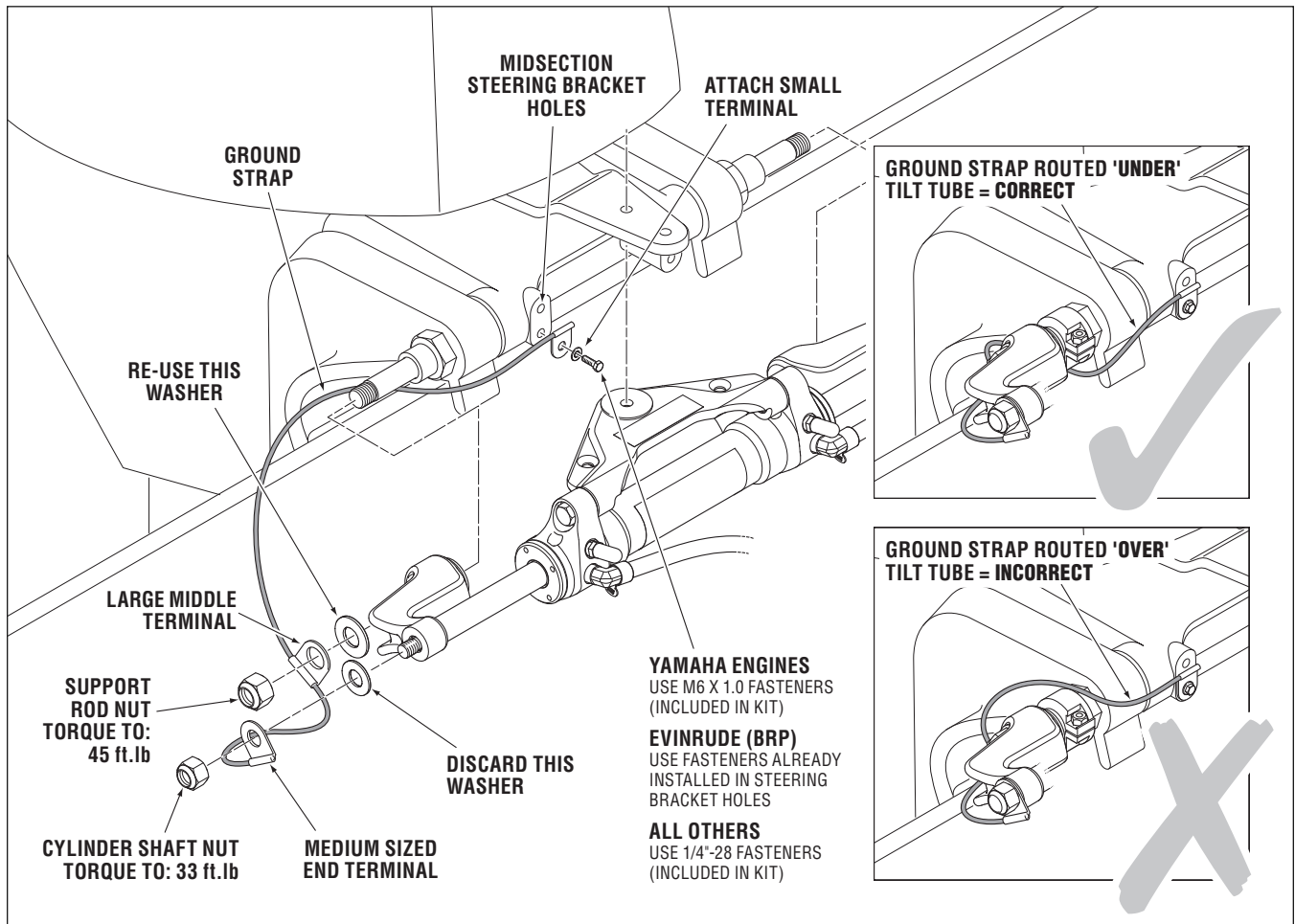

Figure 10. Ground Strap Installation.

Tie Bar Installation

NOTICE

For Tournament Type Systems refer to Installation Book 48 included with your steering cylinder.

! WARNING

The steering equipment shown is for use in boats that are used in a 'normal' fashion. For ALL performance orientated, or, any boat that is rigged with engines that exceed 300HP per engine, SeaStar recommends the use of the Tournament Type Steering Cylinders and Tie bars. If you have any questions in regards to your installation, please contact SeaStar Solutions.

! WARNING

Refer to page 7 of your installation instructions for important warnings and information regarding the correct installation of your SeaStar hydraulic hose.

Cut the threaded end of the tie bar and tube to length using the following formulas below:

! CAUTION

The CD dimension must include allowance for engine toe in/out as required, or recommended by the engine manufacturer. Failing to observe toe in/out recommendations may result in harder than normal steering effort.

! WARNING

At the time of installation and any other time thereafter, the threaded rod must always fully cover inspection hole '1' of the rod end, but never inspection hole '2' Failing to observe this warning may result in one engine becoming separated from the steering system resulting in property damage and/or personal injury. The SeaStar tie bar is designed for use on SeaStar cylinders only. It may not be compatible with other cylinders.

Note: Maximum standard engine center = 3ft. (0.9m)

H06001

Note: Engine or tiller centers=CD

Y=CD - (subtract) 18½" (375mm)

X=CD - (subtract) 14¾" (464mm)

Note: H06001 Minimum Engine centers = 26" (660mm)

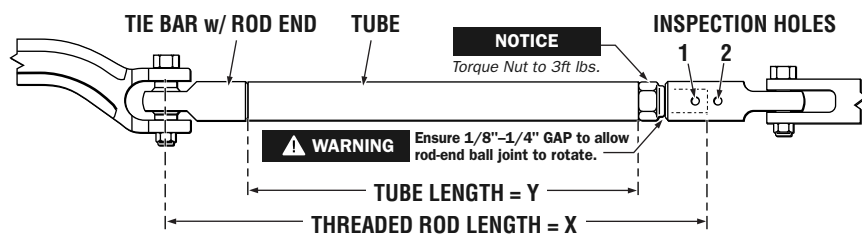

Figure 11.

H06002

Y=CD - (subtract) 22½" (572mm)

X=CD - (subtract) 19¼" (489mm)

Note: OMC 200-225HP (1982-1992) & OMC FICHT 90-225HP (1982-1992)
H06002 Minimum Engine centers = 29" (737mm)

All other makes and models

H06002 Minimum Engine centers = 27" (685mm)

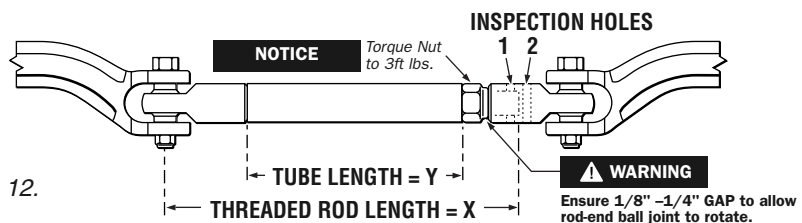

Figure 12.

H06003

Y=CD - (subtract) 13³/₈" (340mm)
 X=CD - (subtract) 10¹/₈" (257mm)

Note: H06003 Minimum Engine centers = 26" (660mm)

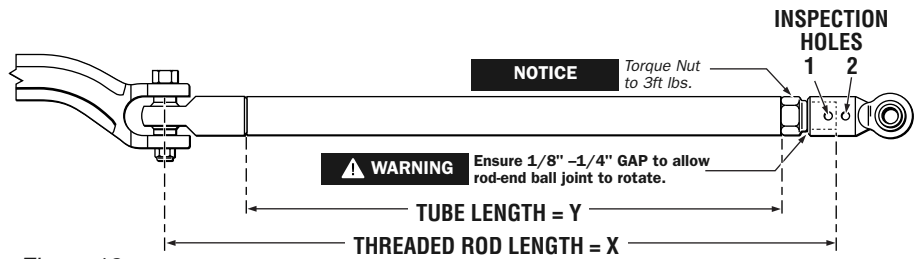

Figure 13.

CAUTION

Ensure that the steering cylinders are able to be fully stroked out. If the cylinders are not able to fully stroke out, the tiebar may have to be removed for bleeding.

Positional O-Ring Horizontal and Vertical Tee Fitting Installation/Realignment

CAUTION

DO NOT attempt to install NPT pipe fittings into the cylinder hose fitting ports. Doing so will lead to irreparable damage to the cylinder. **ONLY** use ORB hose fittings provided by SeaStar Solutions.

Cylinder Fitting Installation (If required.)

WARNING

Failure to properly tighten the locknut (item 1) may lead to loss of steering control. Loss of steering control may result in unpredictable boat behavior, collision with an obstacle and/or ejection from vessel, leading to property damage, personal injury and/or death.

WARNING

SeaStar Solutions recommends that the hose and hose fittings are checked on a regular basis to ensure the safe operation of the steering system.

1. Back off lock nut (item 1, Figure 14), counter-clockwise, until it stops.
2. Thread fitting into cylinder body until fitting washer (item 2, Figure 14) contacts the face of the cylinder port. Tighten hand tight, **DO NOT TORQUE FITTING AT THIS TIME.**
3. Position fitting to desired orientation by turning it counter-clockwise to a **MAXIMUM** of 1 full turn.
4. While holding fitting with a wrench, tighten the locknut (item 1, Figure 14) and torque to 40–43 ft-lb.
5. Purge system as per your cylinder instruction manual.

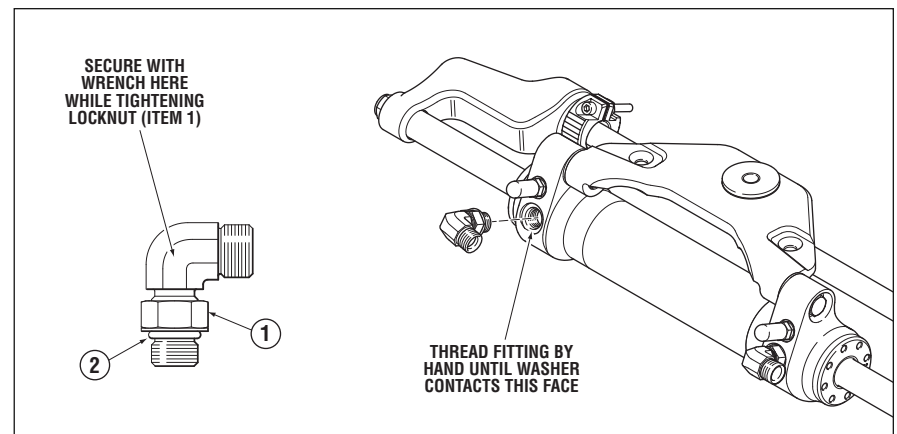

Figure 14.

SeaStar Pro Cylinder Part # HC6345-3 and HC6358-3

Installation Instructions for Keyed support rod to Keyed Bracket

1. Refer to steps 1–4 as shown on page 9 of this installation manual.
2. Place the supplied square 3/16" Keys (044901) in both sides of the support rod.
3. Install support brackets onto the support rod ensuring the aligning keys (044901) are in place.
4. continue with step 6 on page 9 of this manual.

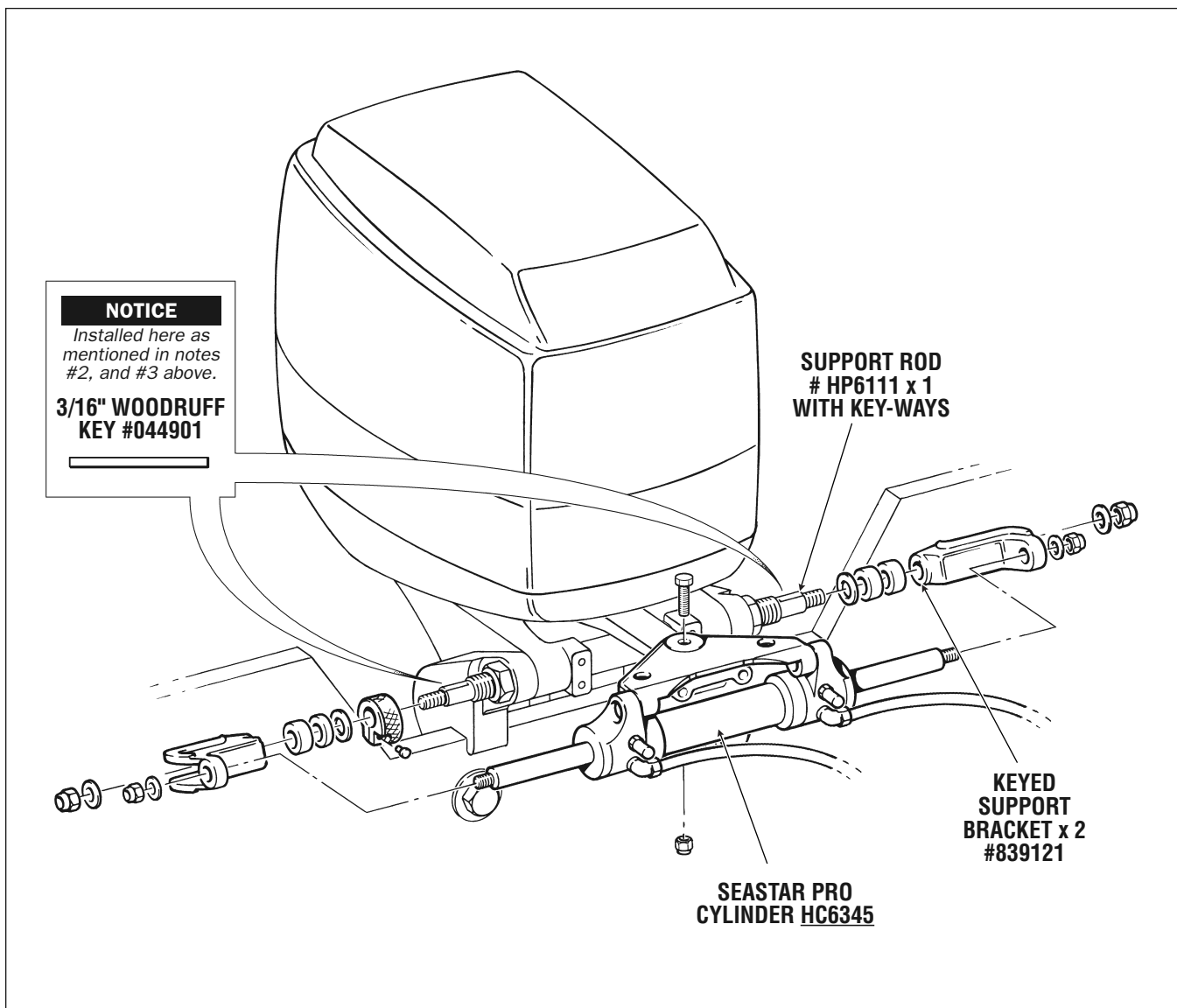

Figure 15. (HC6345 Cylinder Shown.)

INSTALLATION INSTRUCTIONS

SINGLE ENGINE

⚠ WARNING Refer to page 44 for correct torque specifications of all installation hardware.

ENGINE MANUFACTURER	YEAR	MODEL	CYLINDER	NOTE
FORCE	1985 TO 1995	90–150 HP	HC5345-3	(See Fig. 16a)
HONDA	1992 TO DATE	30–50 HP	HC5345-3	Requires Spacer Kit HO5090 (See Fig. 16a)
	1996 TO DATE	75–90 HP	HC5345-3	(See Fig. 16a)
	1998 TO 2009	115–130 HP	HC5347-3	Ref. page 22 for Installation Instructions
	2001 TO DATE	150–250 HP 4 Stroke	HC5345-3	(See Fig. 16b)
	2010 TO DATE	115 HP	HC5345-3	(See Fig. 16b)

Figure 16.

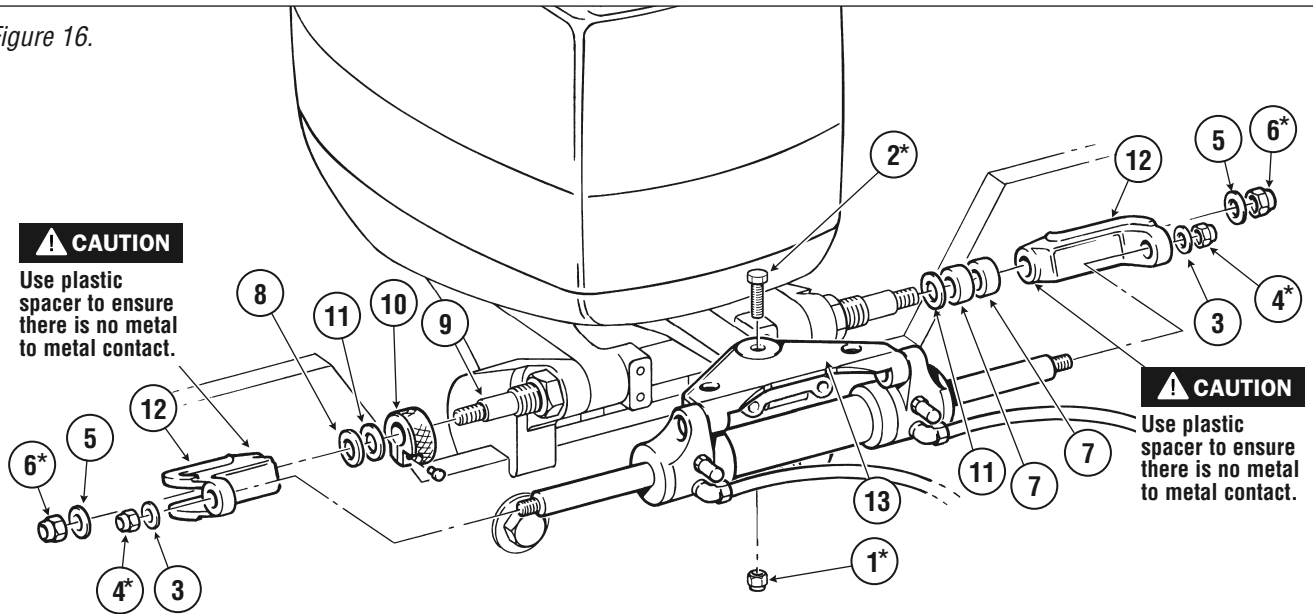

⚠ CAUTION
Use plastic spacer to ensure there is no metal to metal contact.

⚠ CAUTION
Use plastic spacer to ensure there is no metal to metal contact.

Figure 16a

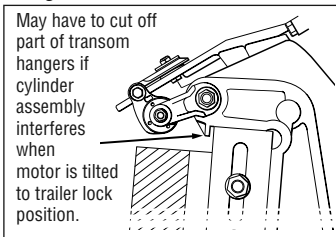

Honda 75/90 to 1998

Figure 16b

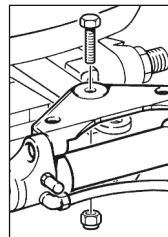

Honda 150–250HP
4 STROKE

Figure 16c

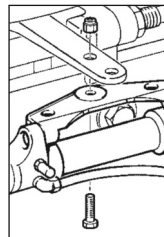

Force 150HP
2007 – Date

⚠ WARNING

Fully tilting the engine may cause the steering cylinder to interfere with the transom and/or splashwell. Possible damage to the steering system can result. Ensure that the cylinder is free from interference at all times.

* Refer to page 44 for correct torque specifications.

ITEM	PART #	QTY	DESCRIPTION
*1	113529	1	Nut, 3/8" NF Nylok® SS
*2	113225	1	HHCS 3/8 UNJF x 1.35 HSS
3	731625	2	Washer Flat, 7/16" SS
*4	731720	2	7/16" NF Nylok® SS
5	202027	2	Washer, Flat 1/2" SS
*6	192126	2	Nut 1/2" NF Nylok® NI PLT BR
7	995876	2	Spacer, Thick, Plastic
8	996689	1	Spacer, Thin, Plastic

ITEM	PART #	QTY	DESCRIPTION
9	730229	1	Support Rod
10	828085	1	Adjusting Nut & Screw SS, Teflon Coated
11	202300	2	Washer, Flat 5/8" SS
12	839120	2	Support Brackets
13	444005	1	Pivot Mount Cylinder
14	728994	1	Spacer, Medium (Not Used)
15	113330	1	HHCS 3/8" NF x 1-3/8" SS

INSTALLATION INSTRUCTIONS

SINGLE ENGINE

⚠ WARNING Refer to page 44 for correct torque specifications of all installation hardware.

ENGINE MANUFACTURER	YEAR	MODEL	CYLINDER	NOTE
MERCURY/MARINER	1984-TO 1989	75-250 HP	HC5345-3	(See Fig. 17a)
	1990-TO DATE	75-250 HP	HC5345-3	
	1995-TO 1997	40, 50 & 60 HP	HC5345-3	Requires Spacer Kit H05090
	1998-TO DATE	40, 50 & 60 HP	HC5345-3	Requires Spacer Kit H05090 (See Fig. 17b)
	2002-TO DATE	115XS-300XS	HC6345-3	
	2002-TO DATE 2004-TO DATE	90-225 HP Optimax 150-200 HP Verado	HC5345-3 HC5345-3	(See Fig. 17c) (See Fig. 17d)
NISSAN	1990-TO DATE	120-140 HP	HC5345-3	
TOHATSU	1990-TO DATE	120-140 HP	HC5345-3	

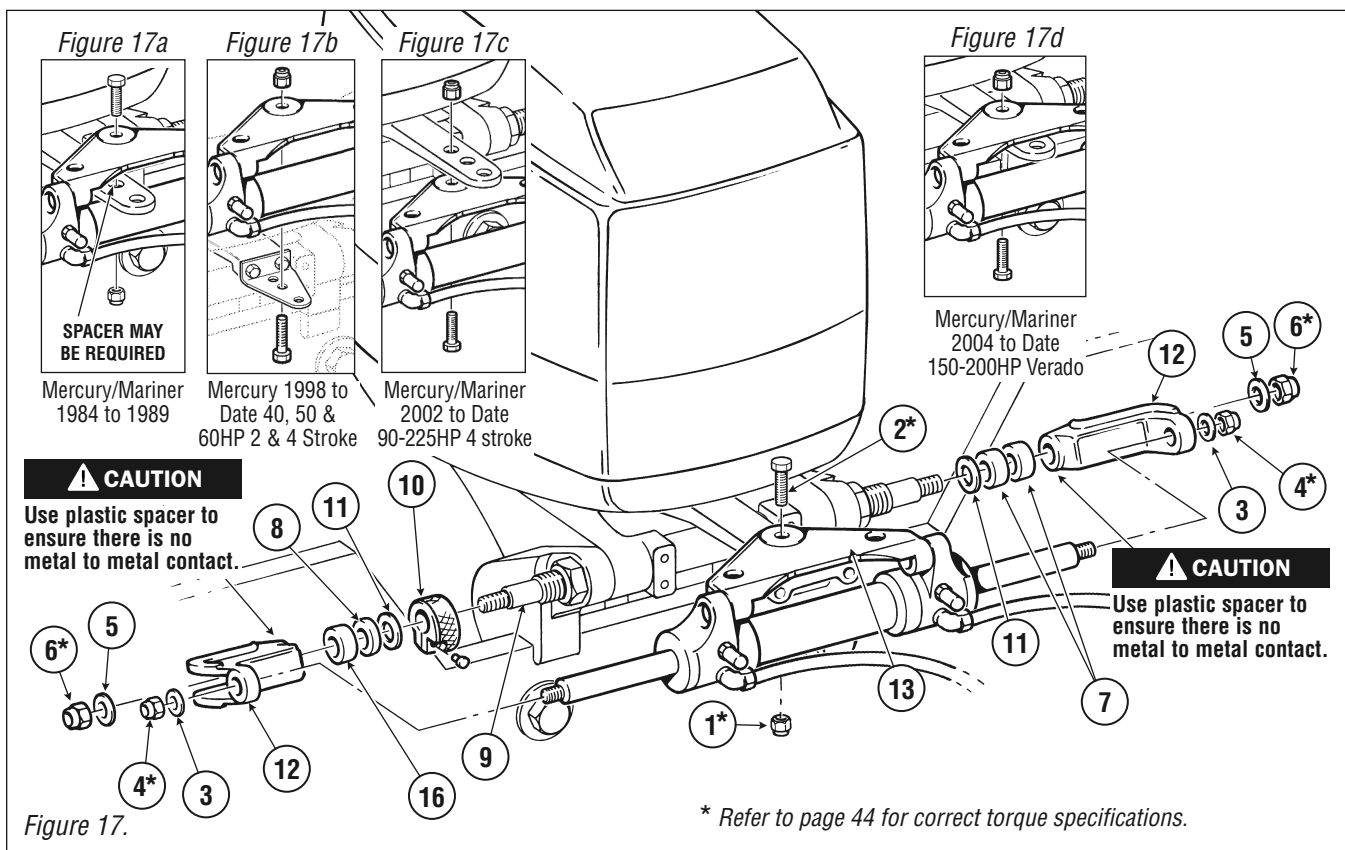

ITEM	PART #	QTY	DESCRIPTION
*1	113529	1	Nut, 3/8" NF Nylok® SS
*2	113225	1	HHCS 3/8UNJFX1.35 HSS
3	731625	2	Washer Flat, 7/16" SS
*4	731720	2	7/16" NF Nylok® SS
5	202027	2	Washer, Flat 1/2" SS
*6	192126	2	Nut 1/2" NF Nylok® ni plt br
7	995876	2	Spacer, Thick, Plastic
8	996689	1	Spacer, Thin, Plastic
9	730229	1	Support Rod

ITEM	PART #	QTY	DESCRIPTION
10	828085	1	Adjusting Nut & Screw SS, Teflon Coated
11	202300	2	Washer, Flat 5/8" SS
12	839120	2	Support Brackets
13	444005	1	Pivot Mount Cylinder
14	728994	1	Spacer, Medium (Not Used)
15	113330	1	HHCS, 3/8" NF x 1-3/8" SS
*16	H05090	n/a	Refer to page 10 for specific spacer installation instructions.

INSTALLATION INSTRUCTIONS

SINGLE ENGINE

WARNING Refer to page 44 for correct torque specifications of all installation hardware.

ENGINE MANUFACTURER	YEAR	MODEL	CYLINDER	NOTE
JOHNSON/EVINRUDE	1977 TO 1990	65–300 HP	HC5348-3	Refer Figure 18b.
	1977 TO 1988	250–300 HP, V8	HC5342	Refer to SeaStar Book 1
	1991 TO 2006	40–250 HP	HC5345-3	See Figure 18a.
	1997 TO 2006	75–300 HP FICHT	HC5345-3	
	1998 TO DATE	40–140 HP 4 Stroke	HC5358-3	Refer to Figure 22d on page 21 for Installation Instructions. Requires Spacer Kit HO5090
	2007 TO DATE	3.3L V6 200–250 HP 3.4L V6 250H.O.–300 HP	HC5345-3 HC5345-3	

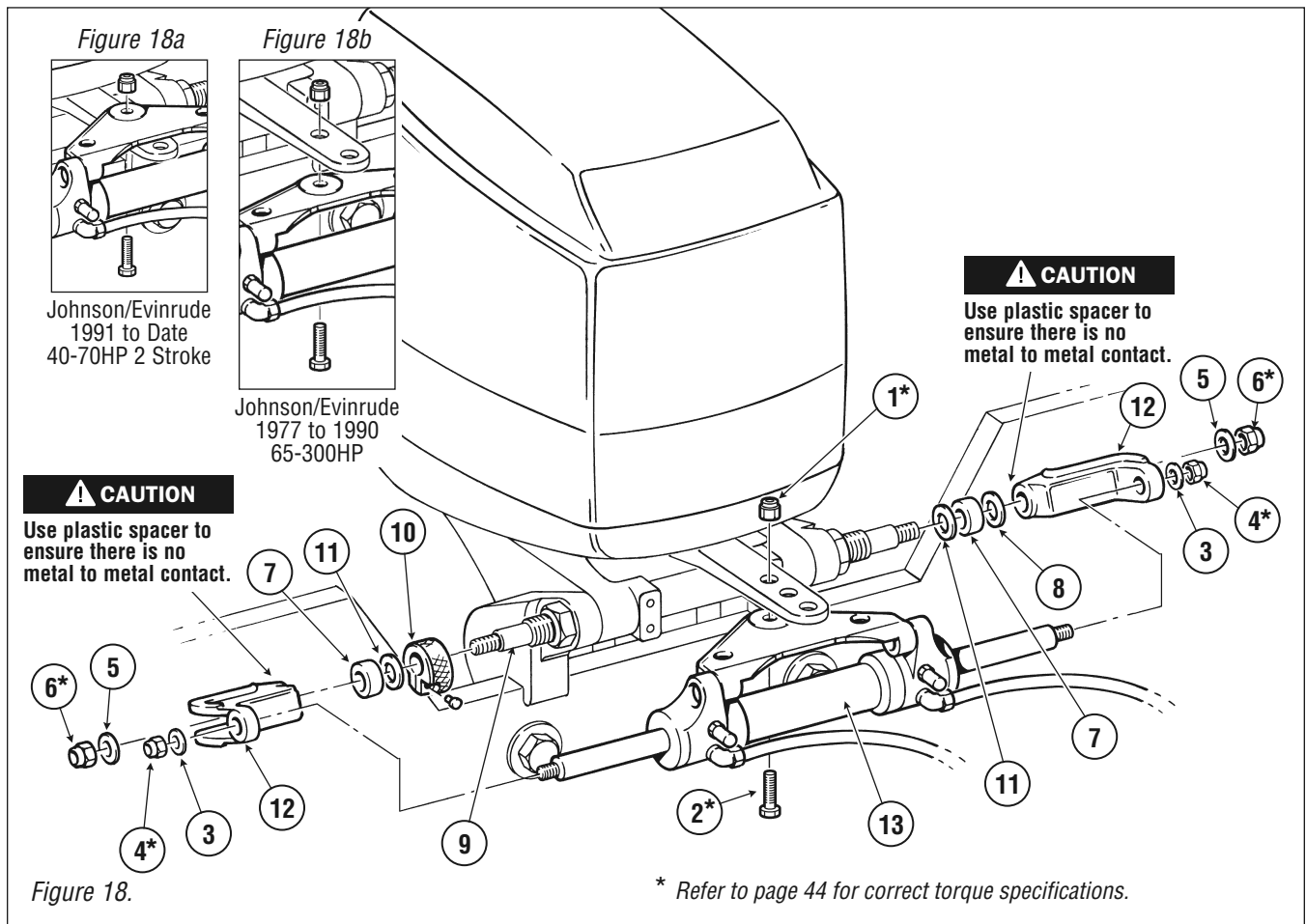

ITEM	PART #	QTY	DESCRIPTION
*1	113529	1	Nut, 3/8" NF Nylok® SS
*2	113225	1	HHCS 3/8UNJFX1.35 HSS
3	731625	2	Washer Flat, 7/16" SS
*4	731720	2	7/16" NF Nylok® SS
5	202027	2	Washer, Flat 1/2" SS
*6	192126	2	Nut 1/2" NF Nylok® ni plt br
7	995876	2	Spacer, Thick, Plastic
8	996689	1	Spacer, Thin, Plastic
9	730229	1	Support Rod

ITEM	PART #	QTY	DESCRIPTION
10	828085	1	Adjusting Nut & Screw SS, Teflon Coated
11	202300	2	Washer, Flat 5/8" SS
12	839120	2	Support Brackets
13	444005	1	Pivot Mount Cylinder
14	728994	1	Spacer, Medium (Not Used)
15	113330	1	HHCS, 3/8" NF x 1-3/8" SS

INSTALLATION INSTRUCTIONS

SINGLE ENGINE

⚠ WARNING Refer to page 44 for correct torque specifications of all installation hardware.

ENGINE MANUFACTURER	YEAR	MODEL	CYLINDER	NOTE
YAMAHA	1998 TO 2007	40-90 HP 2 Stroke	HC5345-3	Engine clamp brackets must be modified (cut or ground) and the engine through bolted onto transom or interference will occur restricting engine trim and tilt. Requires spacer kit H05090. (See Fig. 19a & 19c).
	2002 TO DATE	25-70 HP 4 Stroke	HC5348-3	See Fig. 19b. Requires spacer kit H05090.

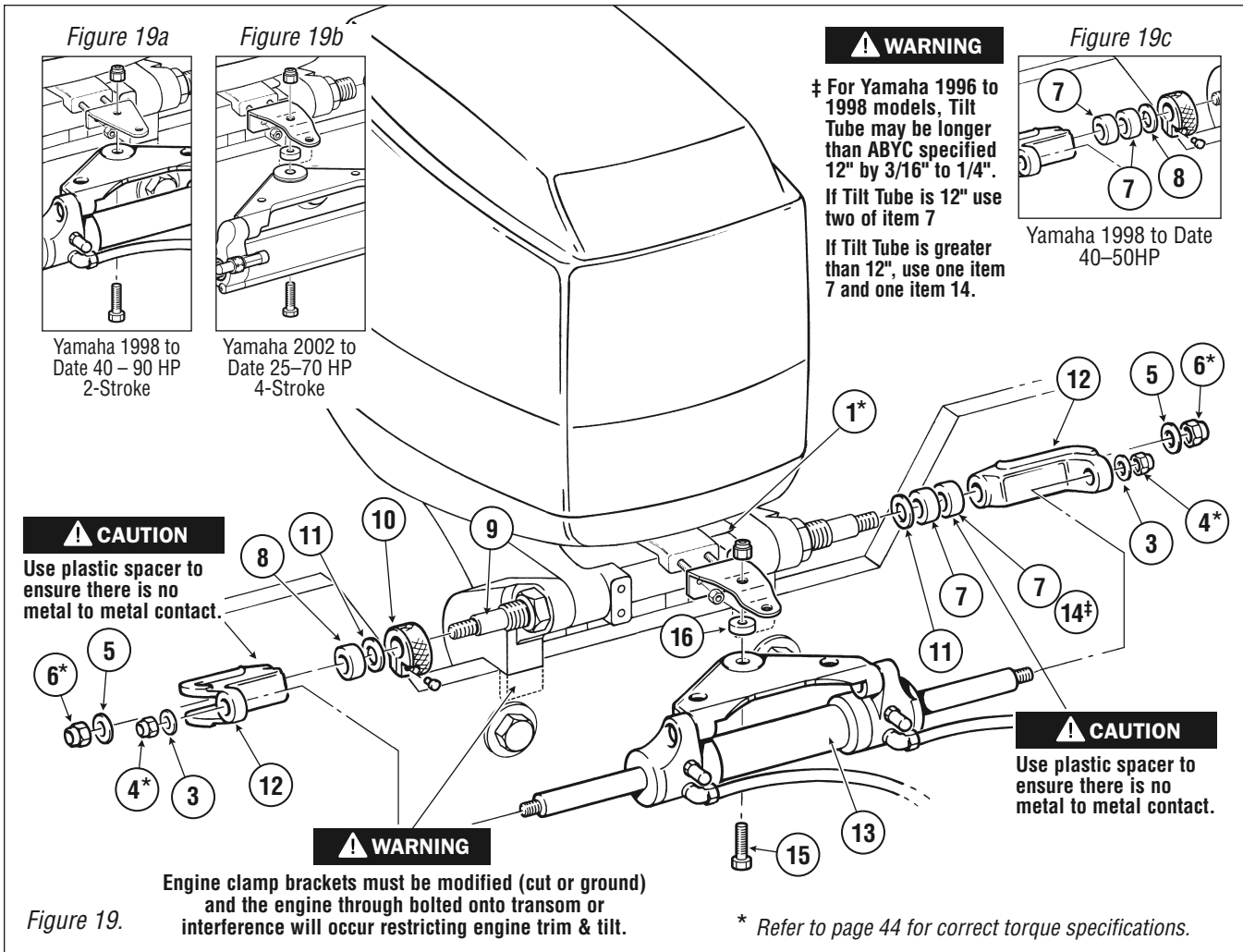

Figure 19.

* Refer to page 44 for correct torque specifications.

ITEM	PART #	QTY	DESCRIPTION
*1	113529	1	Nut 3/8" NF Nylok® SS
*2	113225	1	HHCS 3/8UNJFX1.35 HSS (Not Used)
3	731625	2	Washer Flat, 7/16" SS
*4	731720	2	Nut 7/16" NF Nylok® SS
5	202027	2	Washer, Flat 1/2" SS
*6	192126	2	Nut 1/2" NF Nylok® ni plt br
7	995876	4	Spacer, Thick. Plastic
8	996689	1	Spacer, Thin, Plastic
9	730229	1	Support Rod

ITEM	PART #	QTY	DESCRIPTION
10	828085	1	Adjusting Nut & Screw SS, Teflon Coated
11	202300	2	Washer, Flat 5/8" SS
12	839120	2	Support Brackets
13	444005	1	Pivot Mount Cylinder
*14	728994	1	Spacer, Medium (Maybe Used)
15	113330	1	HHCS 3/8" NF x 1-3/8" SS
16	H05090		Refer to page 10 for specific spacer installation instructions.

INSTALLATION INSTRUCTIONS

SINGLE ENGINE

⚠ WARNING Refer to page 44 for correct torque specifications of all installation hardware.

ENGINE MANUFACTURER	YEAR	MODEL	CYLINDER	NOTE
YAMAHA	1986 TO 2004	100–200 HP 2 Stroke	HC5345-3	1997 to Date 80–100HP 4 Stroke (See Fig. 20a) 2001 to Date 115HP 4 Stroke (See Fig. 20b). <i>MUST use high strength tiller bolt, Kit HA5822.</i> <i>Bolt head is marked with SEASTAR ARP.</i>
	1990 TO 2004	150–300 HP 2 Stroke	HC5345-3	
	1997 TO DATE	F75–F300 HP Inc. 4.2 V6	HC5345-3	
	2007 TO DATE	F300–F350 HP 5.3 V8	HC5345-3	

** Interference MAY occur when engine is positioned in lowest mounting hole on transom. HC5345-3 will allow more space for unrestricted mounting.

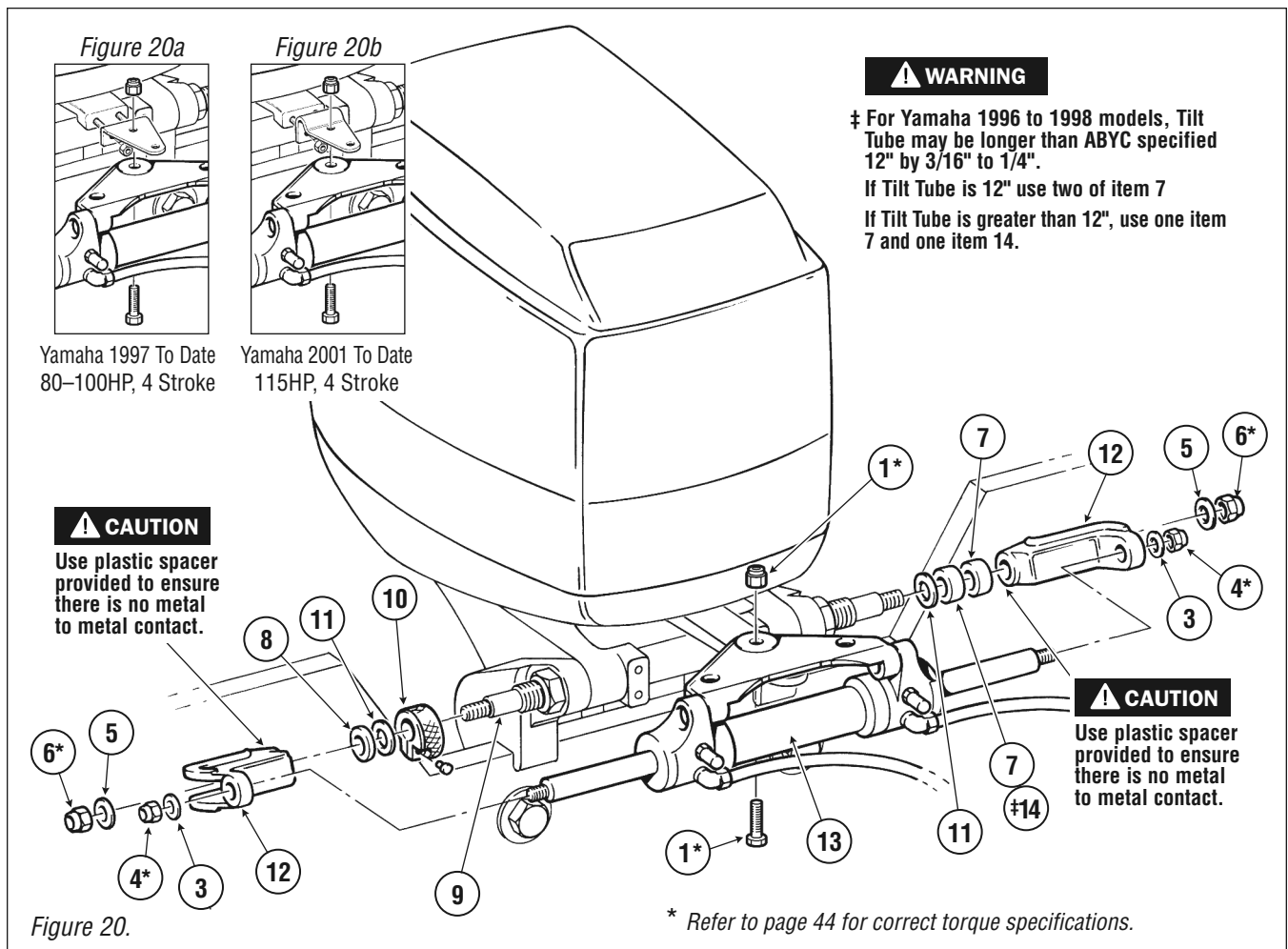

Figure 20.

ITEM	PART #	QTY	DESCRIPTION
*1	113529	1	Nut, 3/8" NF Nylok® SS
*2	113225	1	HHCS 3/8UNJFX1.35 HSS
3	731625	2	Washer Flat, 7/16" SS
*4	731720	2	Nut, 7/16" NF Nylok® SS
5	202027	2	Washer, Flat 1/2" SS
*6	192126	2	Nut 1/2" NF Nylok® ni plt br
7	995876	2	Spacer, Thick
8	996689	1	Spacer, Thin

ITEM	PART #	QTY	DESCRIPTION
9	730229	1	Support Rod
10	828085	1	Adjusting Nut & Screw SS, Teflon Coated
11	202300	2	Washer, Flat 5/8" SS
12	839120	2	Support Brackets
13	828009	1	Pivot Mount Cylinder
*14	728994	1	Spacer, Medium (Some 1996 to 1998)
15	113350	1	HHCS 3/8" NF x 1-1/2" SS

INSTALLATION INSTRUCTIONS

SINGLE ENGINE

⚠ WARNING Refer to page 44 for correct torque specifications of all installation hardware.

ENGINE MANUFACTURER	YEAR	MODEL	CYLINDER	NOTE
YAMAHA	2010 TO DATE	4.2L V6	HC5445-3	Stroke reduced cylinder.

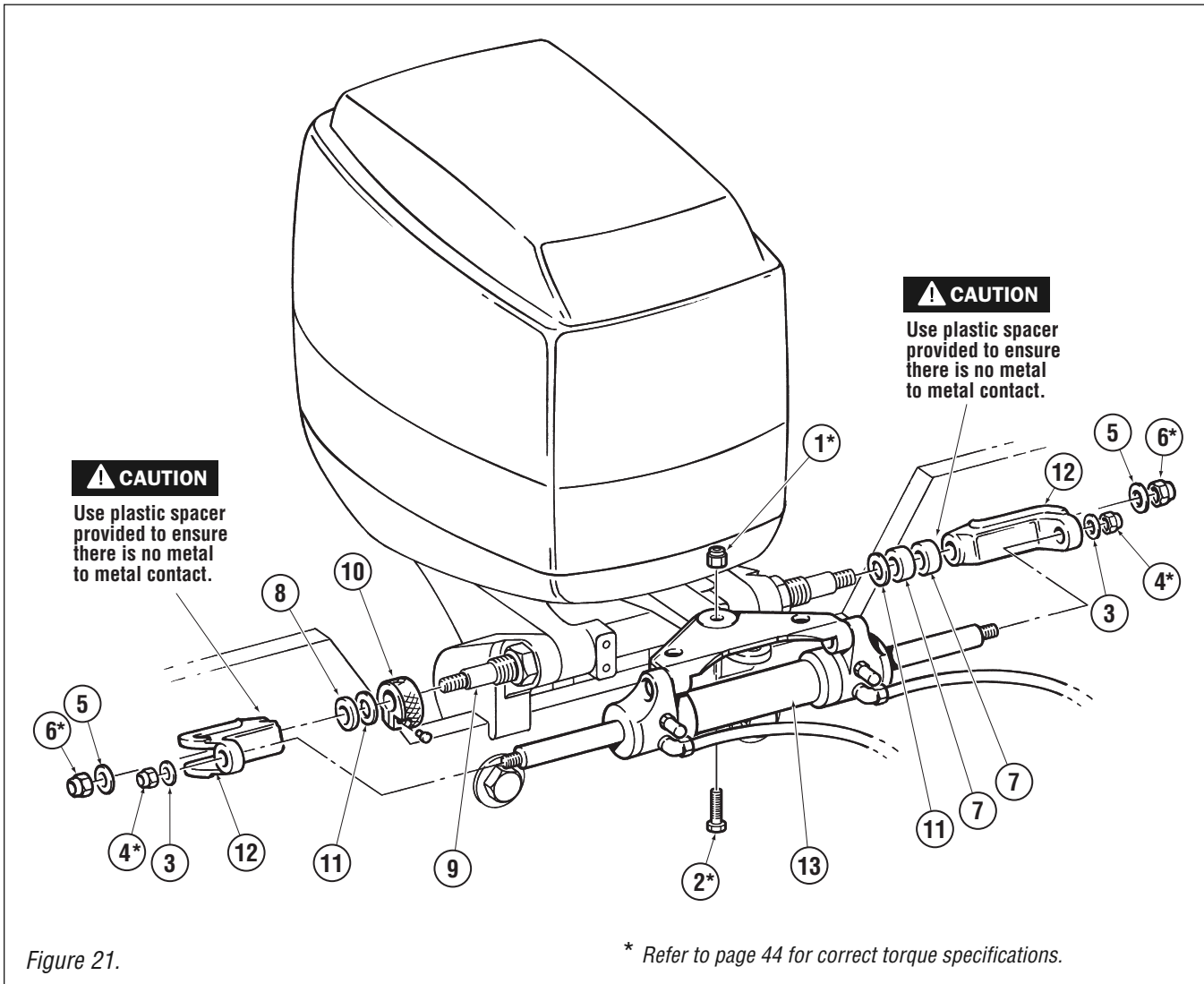

Figure 21.

* Refer to page 44 for correct torque specifications.

ITEM	PART #	QTY	DESCRIPTION
*1	113529	1	Nut, 3/8" NF Nylok® SS
*2	113225	1	HHCS 3/8" UNJF x 1.35" HSS
3	731625	2	Washer Flat, 7/16" SS
*4	731720	2	7/16" NF Nylok SS
5	202027	2	Washer, Flat 1/2" SS
*6	192126	2	Nut 1/2" NF Nylok® ni plt br
7	995876	2	Spacer, Thick, Plastic
8	996689	1	Spacer, Thin, Plastic
9	730229	1	Support Rod

ITEM	PART #	QTY	DESCRIPTION
10	828085	1	Adjusting Nut and Screw SS, Teflon Coated
11	202300	2	Washer, Flat 5/8" SS
12	839120	2	Support Brackets
13	HC5445-3	1	Pivot Mount Cylinder
14	728994	1	Spacer, Medium (Not Used)
15	113330	1	HHCS, 3/8" NF x 1-3/8" SS

INSTALLATION INSTRUCTIONS

SINGLE ENGINE

WARNING Refer to page 44 for correct torque specifications of all installation hardware.

ENGINE MANUFACTURER	YEAR	MODEL	CYLINDER	NOTE
SUZUKI	1986 TO DATE	150-300 HP	HC5345-3	See Fig. 22c for locating on tiller.
	1996 ONLY	115-140 HP	HC5348-3	
	1987 TO 2002	115-140 HP	HC5345-3	May req. Spacer Kit HO5090 (See Fig. 22a & 22b)
	1990 TO 2000	90-100 HP	HC5345-3	
	1998 TO DATE	40-140 HP 4 Stroke	HC5358-3	Requires Spacer Kit HO5090 (See Fig. 22d)

Figure 22.

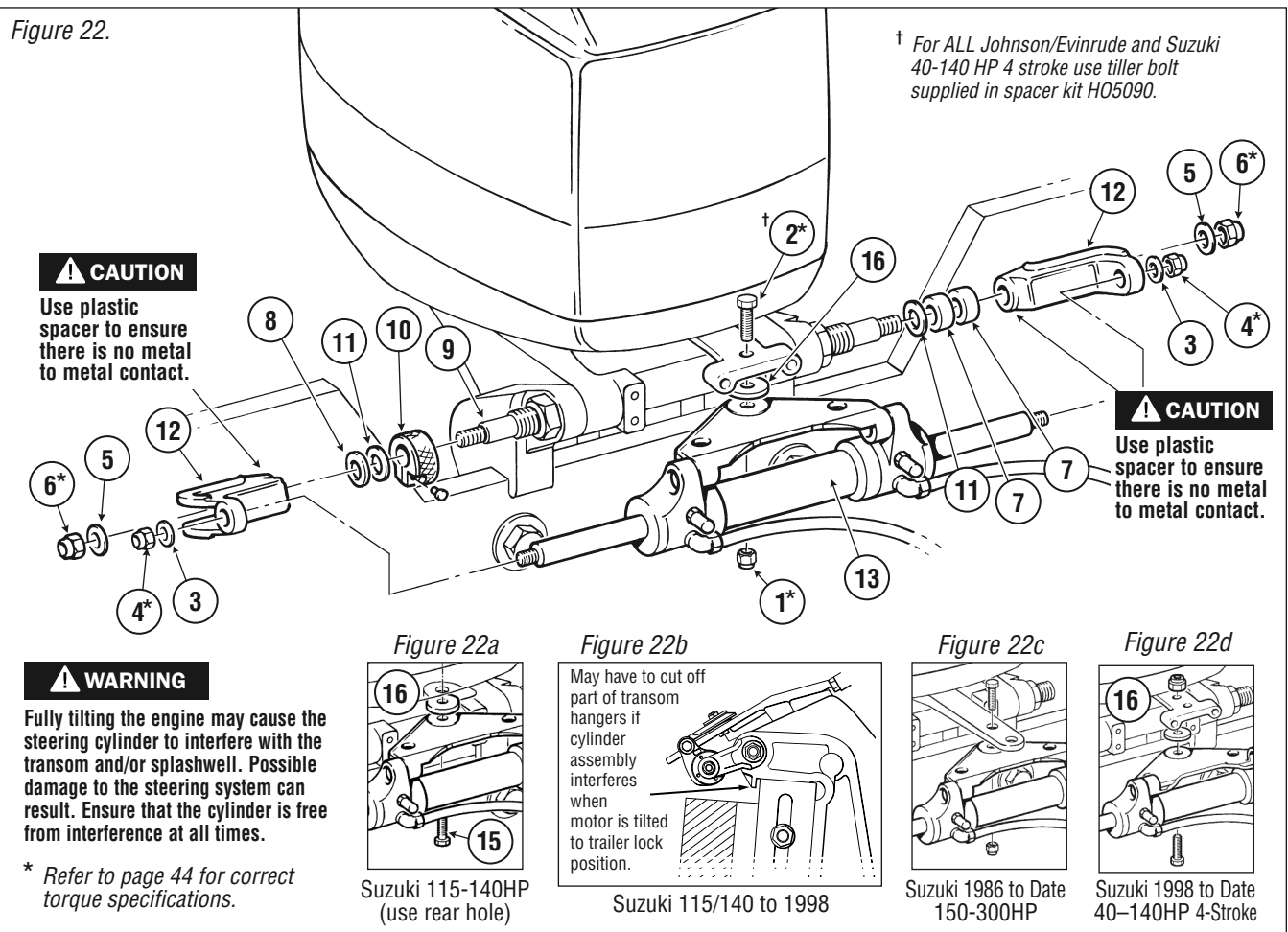

ITEM	PART #	QTY	DESCRIPTION
*1	113529	1	Nut, 3/8" NF Nylok® SS
*2	113225	1	HHCS 3/8UNJFX1.35 HSS
3	731625	2	Washer Flat, 7/16" SS
*4	731720	2	7/16" NF Nylok® SS
5	202027	2	Washer, Flat 1/2" SS
*6	192126	2	Nut 1/2" NF Nylok® ni plt br
7	995876	2	Spacer, Thick, Plastic
8	996689	1	Spacer, Thin, Plastic
9	730229	1	Support Rod

ITEM	PART #	QTY	DESCRIPTION
10	828085	1	Adjusting Nut & Screw SS, Teflon Coated
11	202300	2	Washer, Flat 5/8" SS
12	839120	2	Support Brackets
13	444005	1	Pivot Mount Cylinder
14	728994	1	Spacer, Medium (Not Used)
15	113330	1	HHCS 3/8" NF x 1-3/8" SS
16	HO5090	n/a	Refer to page 10 for specific spacer installation instructions.

INSTALLATION INSTRUCTIONS

SINGLE ENGINE

For HC5347-3 Cylinder Installation **ONLY**

⚠ WARNING Refer to page 44 for correct torque specifications of all installation hardware.

ENGINE MANUFACTURER	YEAR	MODEL	CYLINDER	NOTE
HONDA	1998 TO 2009	115-130 HP	HC5347-3	Refer to page 34 for Twin Engine Applications
	2010 TO DATE	115HP	HC5345-3	Refer to page 15 for details

Figure 23.

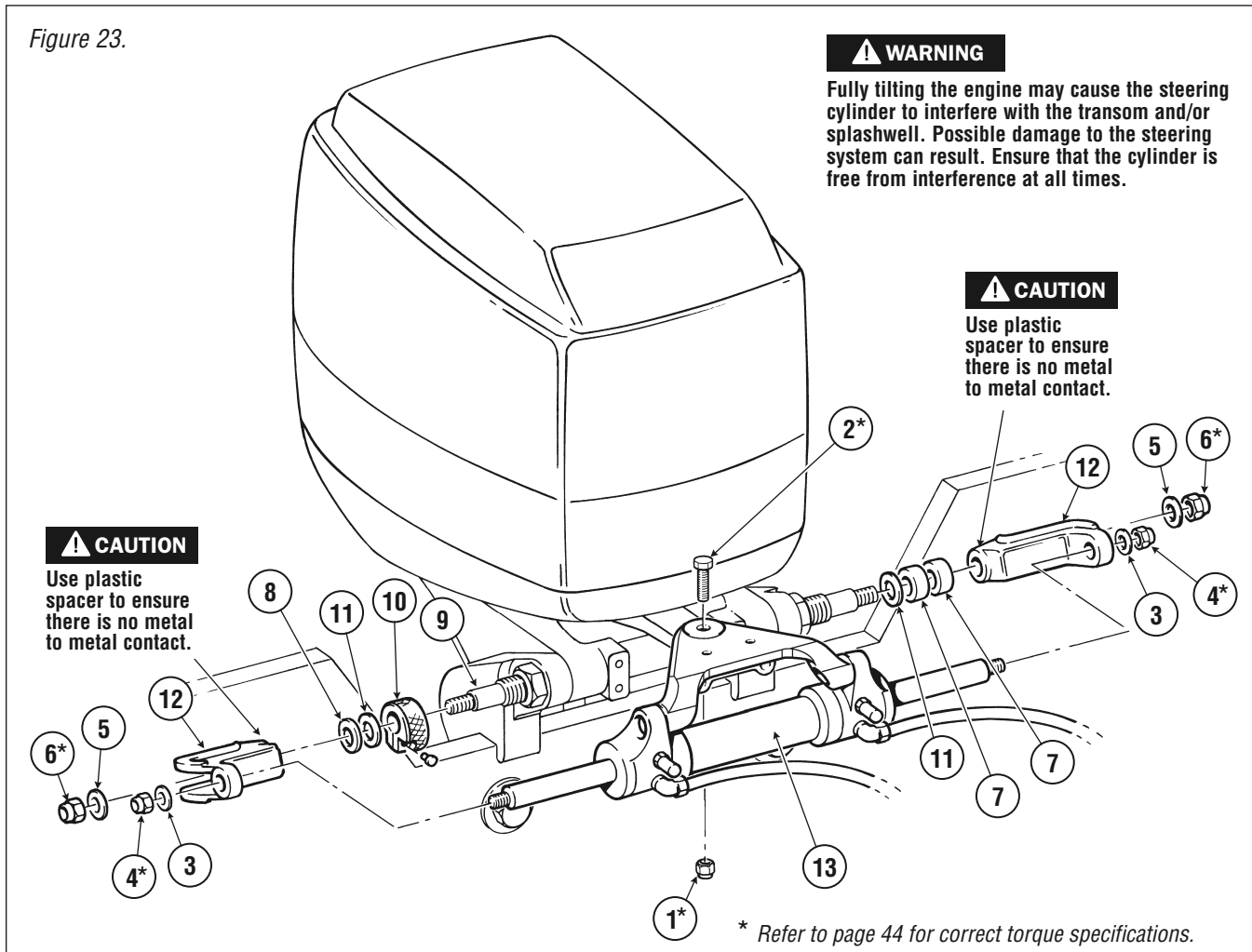

ITEM	PART #	QTY	DESCRIPTION
*1	113529	1	Nut, 3/8" NF Nylok® SS
*2	113225	1	HHCS 3/8UNJFX1.35 HSS
3	731625	2	Washer Flat, 7/16" SS
*4	731720	2	7/16" NF Nylok® SS
5	202027	2	Washer, Flat 1/2" SS
*6	192126	2	Nut 1/2" NF Nylok® ni plt br
7	995876	2	Spacer, Thick, Plastic
8	996689	1	Spacer, Thin, Plastic
9	730229	1	Support Rod

ITEM	PART #	QTY	DESCRIPTION
10	828085	1	Adjusting Nut & Screw SS, Teflon Coated
11	202300	2	Washer, Flat 5/8" SS
12	839120	2	Support Brackets
13	828003	1	Pivot Mount Cylinder
14	728994	1	Spacer, Medium (Not Used)
15	113330	1	HHCS 3/8" NF x 1-3/8" SS

▲ WARNING The steering equipment noted below is for use in boats that are used in a 'normal' fashion. For ALL performance orientated, or, any boat that is rigged with engines that exceed 300HP per engine, SeaStar Solutions recommends the use of the Tournament Type Steering Cylinders and Tie bars. If you have any questions in regards to your installation, please contact SeaStar Solutions. Refer to page 44 for correct torque specifications of all installation hardware.

INSTALLATION INSTRUCTIONS

TWIN ENGINES

H06001-Single Cylinder Tie Bar Kit

ENGINE MANUFACTURER	YEAR	MODEL	CYLINDER	ENGINE TIE BAR KITS		NOTE
				SINGLE CYL.	DUAL CYL.	
FORCE	1995 TO DATE	90-120 HP	HC5345-3	H06001	HO6002	
HONDA	† 1996 TO DATE	75-90 HP	HC5345-3	H06001	HO6002	Port Cylinder install ONLY. (see Figure 24C) **Requires Spacer Kit HO5090. Trim Engine Hooks if Interference occurs
	†† 1998 TO DATE	30-50 HP	HC5345-3	H06001	HO6002	(See Figure 24B)
	†† 2001 TO DATE	135-250 HP 4 Stroke	HC5345-3	H06001	HO6002	(See Figure 24B)
	2010 TO DATE	115-250 HP 4 Stroke	HC5345-3	H06001	HO6002	(See Figure 24B)
MERCURY/MARINER	1989 TO DATE	75-275 HP	HC5345-3	H06001	HO6002	(See page 26 for Dual Cylinder)
	†† 2002 TO DATE	90-225 HP 4 Stroke	HC5358-3	H06001	HO6002	(See Figure 24D)
	2002 TO DATE	115XS- 300XS	HC6345-3	N/A	N/A	Cylinder req. on every engine (See page 26) MUST use Tournament Cylinders. Must use high strength tiller bolt, Kit HA5822 Bolt head is marked with SEASTAR ARP.

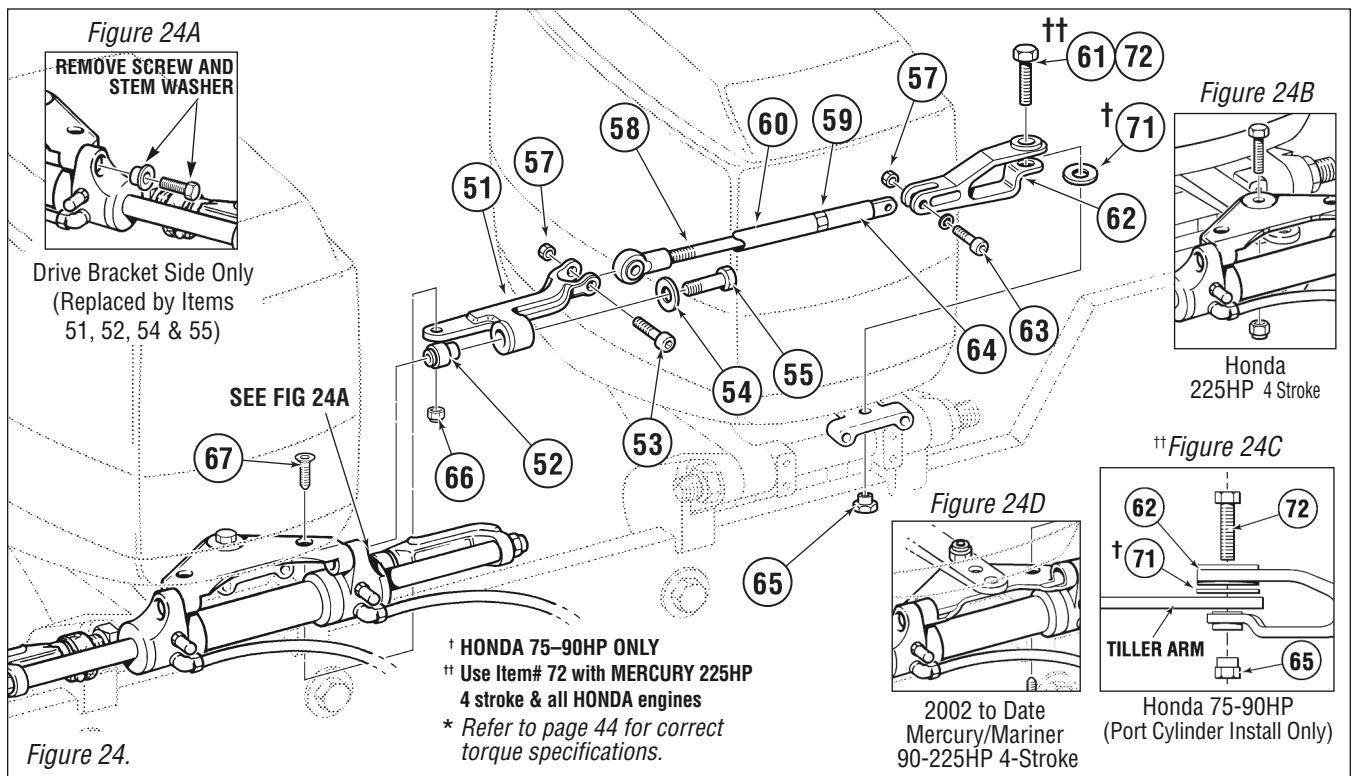

ITEM	PART #	QTY	DESCRIPTION
51	961665	1	Drive Bracket Assembly
52	961686	1	Spacer
*53	186540	1	Shoulder Bolt, 3/8" x 1-1/4", SS
54	010924	1	Washer 5/16" x 3/4" OD SS
*55	961704	1	HHCS 5/16" NC x 2" SS
*56	113529	1	Nut, Nylok®, 3/8" NF, SS (Not used)
*57	704525	2	Nut, Nylok®, 5/16" NC SS
58	722540	1	Tie Bar c/w Ball Joint
*59	192126	1	Nut, Nylok® 1/2" NF, NI PL BR
60	722750	1	Stringer Tube, SS
††61	113222	1	HHCS, 3/8" NF 1-1/4", SS

ITEM	PART #	QTY	DESCRIPTION
62	961495	1	Slave Bracket Assembly
*63	186530	1	Shoulder Bolt, 3/8" x 1" SS
64	961685	1	Rod End SS 1/2" NF
65	961193	1	Threaded Bushing
*66	113021	1	Nut, Nylok®, 5/16" NC, SS, Thin
*67	185901	1	FHSCS, 5/16" NC x 3/4", SS
69	961241	1	Bush, 1/2" OD x 3/8", SS (Not Used)
*70	198767	1	HHCS 3/8" NF x 1-5/8", SS (Not Used)
†71	113600	1	Washer, 3/8" x 1-1/4" OD, SS
††72	116320	1	HHCS, 3/8" NF 1-1/2", SS

INSTALLATION INSTRUCTIONS

TWIN ENGINES

⚠ WARNING The steering equipment noted below is for use in boats that are used in a 'normal' fashion. For ALL performance orientated, or, any boat that is rigged with engines that exceed 300HP per engine, SeaStar Solutions recommends the use of the Tournament Type Steering Cylinders and Tie bars. If you have any questions in regards to your installation, please contact SeaStar Solutions. Refer to page 44 for correct torque specifications of all installation hardware.

H06001-Single Cylinder Tie Bar Kit

ENGINE MANUFACTURER	YEAR	MODEL	CYLINDER	ENGINE TIE BAR KITS SINGLE CYL.	DUAL CYL.	NOTE
YAMAHA	1986 TO 2004	75-300 HP (2 & 4 Stroke)	HC5358-3	H06001	HO6002	See Fig 25b Must use Tournament Cylinders
	2004 TO DATE	3.3L 75-300 HP	HC5358-3	H06001	HO6002	
	2006 TO DATE	4.2L 75-300HP	HC5345-3	H06001	HO6002	
	2007 TO DATE	F350 HP	N/A	N/A	N/A	

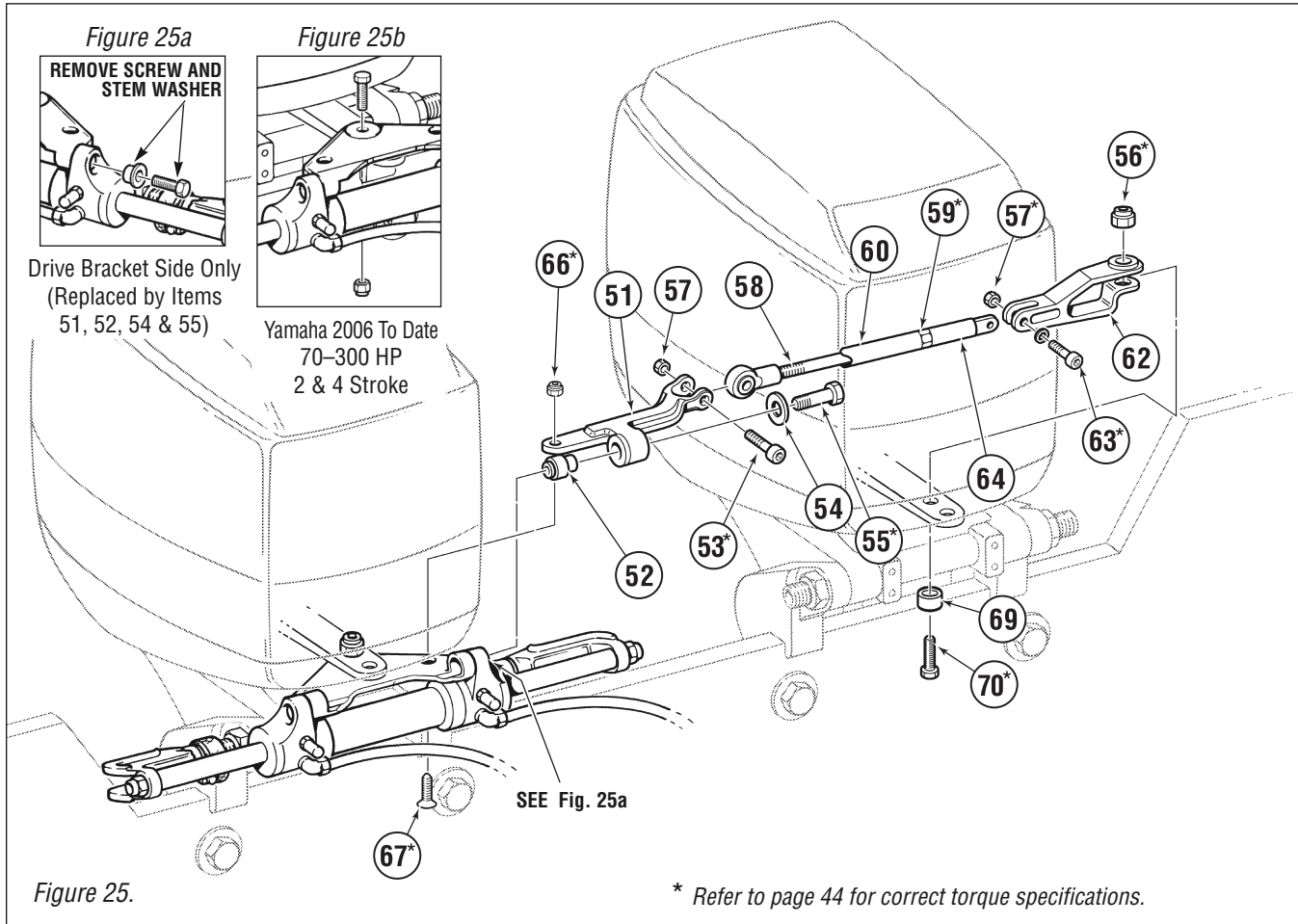

ITEM	PART #	QTY	DESCRIPTION
51	961665	1	Drive Bracket Assembly
52	961686	1	Spacer
*53	186540	1	Shoulder Bolt, 3/8" x 1-1/4", SS
54	010924	1	Washer 5/16" x 3/4" OD, SS
*55	961704	1	HHCS 5/16" NC x 2-1/2", SS
*56	113529	1	Nut, Nylok®, 3/8" NF, SS
*57	704525	2	Nut, Nylok®, 5/16" NC, SS
58	722540	1	Tie Bar c/w Ball Joint
*59	192126	1	Nut, Nylok®, 1/2" NF, NI PL BR
60	722750	1	Stringer Tube, SS

ITEM	PART #	QTY	DESCRIPTION
*61	113222	1	HHCS, 3/8" NF 1-1/4", SS (Not Used)
62	961495	1	Slave Bracket Assembly
*63	186530	1	Shoulder Bolt, 3/8" x 1", SS
64	961685	1	Rod End SS 1/2" NF
65	961193	1	Threaded Bushing (Not Used)
*66	113021	1	Nut, Nylok®, 5/16" NC, SS, Thin
*67	185901	1	FHSCS, 5/16" NC x 3/4", SS
69	961241	1	Bush, 1/2" OD x 3/8", SS
*70	198767	1	HHCS 3/8" NF x 1-5/8", SS
71	113600	1	Washer, 3/8" x 1-1/4" OD, SS (Not Used)

▲ WARNING The steering equipment noted below is for use in boats that are used in a 'normal' fashion. For ALL performance orientated, or, any boat that is rigged with engines that exceed 300HP per engine, SeaStar Solutions recommends the use of the Tournament Type Steering Cylinders and Tie bars. If you have any questions in regards to your installation, please contact SeaStar Solutions. Refer to page 44 for correct torque specifications of all installation hardware.

INSTALLATION INSTRUCTIONS

TWIN ENGINES

H06002-Dual Cylinder Tie Bar Kit

ENGINE MANUFACTURER	YEAR	MODEL	CYLINDER	ENGINE TIE BAR KITS		NOTE
				SINGLE CYL	DUAL CYL	
FORCE	1995 TO DATE	90–120 HP	HC5345-3	H06001	H06002	
HONDA	1996 TO DATE 2001 TO DATE	75–90 HP 150–250 HP	HC5345-3 HC5345-3	H06001 H06001	N/A H06002	See Fig. 26b

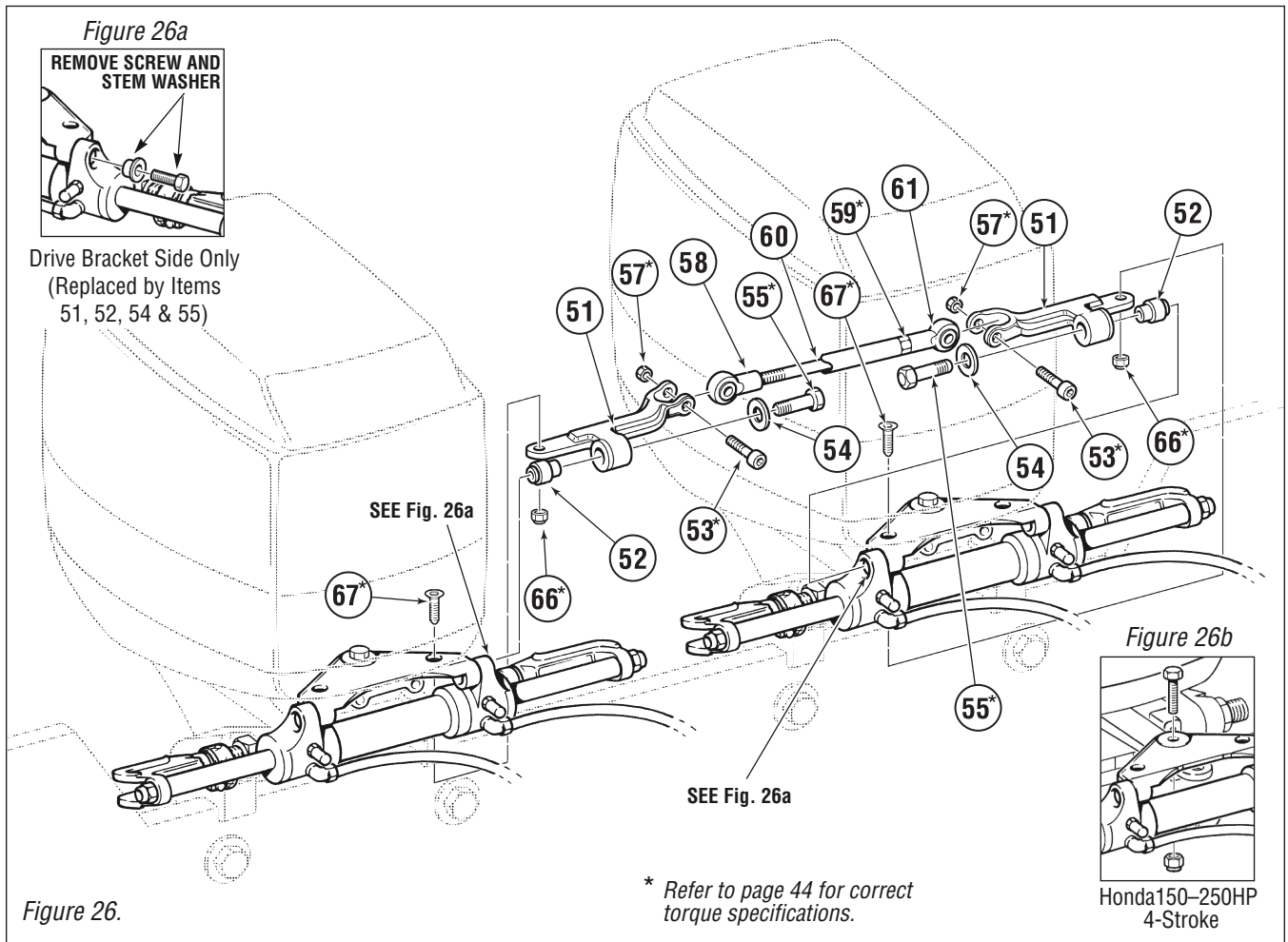

ITEM	PART #	QTY	DESCRIPTION
51	961665	2	Drive Bracket Assembly
52	961686	2	Spacer
*53	186540	2	Shoulder Bolt, 3/8" x 1-1/4", SS
54	010924	2	Washer 5/16" x 3/4" OD SS
*55	961704	2	HHCS 5/16" NC x 2-1/2" SS
*57	704525	2	Nut, Nylok®, 5/16" NC, SS

ITEM	PART #	QTY	DESCRIPTION
58	722543	1	tie bar c/w Ball Joint
*59	192126	1	Nut, Nylok® 1/2" NF, NI PL BR
60	722753	1	Stringer Tube, SS
61	116527	1	Rod End Ball 1/2" SS
*66	113021	2	Nut, Nylok®, 5/16" NC, SS, Thin
*67	185901	2	FHSCS, 5/16" NC x 3/4", SS

INSTALLATION INSTRUCTIONS

TWIN ENGINES

⚠ WARNING The steering equipment noted below is for use in boats that are used in a 'normal' fashion. For ALL performance orientated, or, any boat that is rigged with engines that exceed 300HP per engine, SeaStar Solutions recommends the use of the Tournament Type Steering Cylinders and Tie bars. If you have any questions in regards to your installation, please contact SeaStar Solutions. Refer to page 44 for correct torque specifications of all installation hardware.

H06002-Dual Cylinder Tie Bar Kit

ENGINE MANUFACTURER	YEAR	MODEL	CYLINDER	ENGINE TIE BAR KITS		NOTES
				SINGLE CYL	DUAL CYL	
MERCURY/MARINER	1989 TO DATE	75-275 HP	HC5345-3	H06001	H06002	(See page 29 for Dual Cylinder) Cylinder required on every engine. MUST use Tournament Cylinders. Must use high strength tiller bolt, Kit HA5822. Bolt Head is marked with SEASTAR ARP.
	2002-TO DATE	225 HP 4 Stroke	HC5358-3	H06001	H06002	
	2002-TO DATE	250 XS HP	HC6345-3	N/A	N/A	

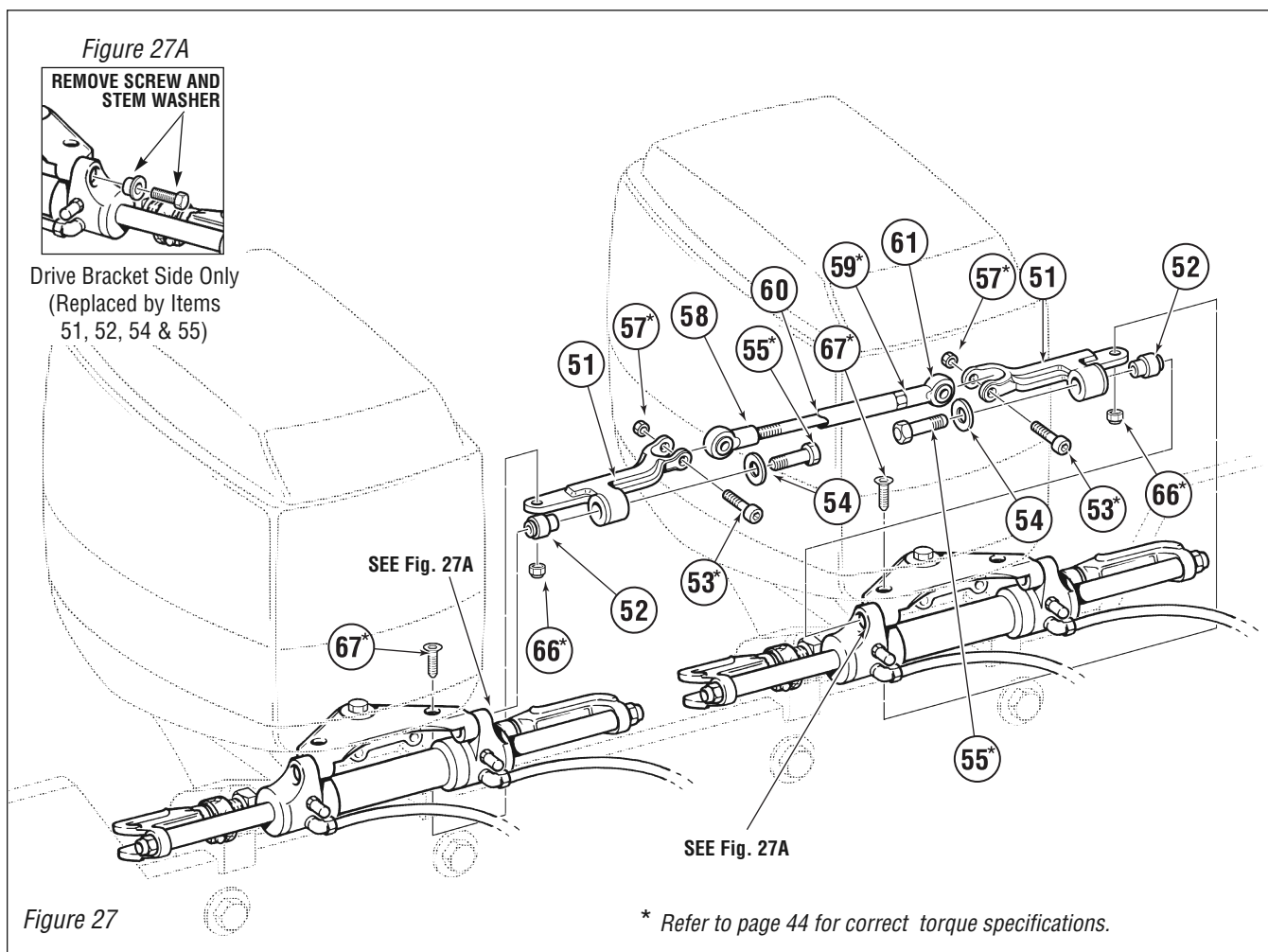

ITEM	PART #	QTY	DESCRIPTION
51	961665	2	Drive Bracket Assembly
52	961686	2	Spacer
*53	186540	2	Shoulder Bolt, 3/8" x 1-1/4", SS
54	010924	2	Washer 5/16" x 3/4" OD SS
*55	961704	2	HHCS 5/16" NC x 2-1/2" SS
*57	704525	2	Nut, Nylok®, 5/16" NC, SS

ITEM	PART #	QTY	DESCRIPTION
58	722543	1	tie bar c/w Ball Joint
*59	192126	1	Nut, Nylok® 1/2" NF, NI PL BR
60	722753	1	Stringer Tube, SS
61	116527	1	Rod End Ball 1/2" SS
*66	113021	2	Nut, Nylok®, 5/16" NC, SS, Thin
*67	185901	2	FHSCS, 5/16" NC x 3/4", SS

⚠ WARNING The steering equipment noted below is for use in boats that are used in a 'normal' fashion. For ALL performance orientated, or, any boat that is rigged with engines that exceed 300HP per engine, SeaStar Solutions recommends the use of the Tournament Type Steering Cylinders and Tie bars. If you have any questions in regards to your installation, please contact SeaStar Solutions. Refer to page 44 for correct torque specifications of all installation hardware.

INSTALLATION INSTRUCTIONS

TWIN ENGINES

H06002-Dual Cylinder Tie Bar Kit

ENGINE MANUFACTURER	YEAR	MODEL	CYLINDER	ENGINE TIE BAR KITS		NOTES
				SINGLE CYL	DUAL CYL	
JOHNSON/EVINRUDE	1991 TO DATE	40–250 HP 2 Stroke	HC5345-3	HO6003	H06002	See Fig. 28d
	1997 TO DATE	75–250 HP FICHT	HC5345-3	HO6003	H06002	See Fig. 28d
	1998 TO DATE	40–140 HP 4 Stroke	HC5358-3	HO6003	H06002	See Fig. 28e Req. Spacer Kit H05090
	2004 TO DATE	75–250 ETech	HC5345-3	HO6003	H06002	See Fig. 28d
	2007 TO DATE	3.3L V6 200–250 HP	HC5345-3	HO6003	H06002	3.4L V6 250H.O.–300HP
SUZUKI	1986 TO DATE	150–300 HP 2 Stroke	HC5345-3	HO6003	H06002	See Fig. 28b
	1986 TO 2002	115–140 HP 2 Stroke	HC5345-3	HO6003	H06002	See Fig. 28c
	1998 TO DATE	40–140 HP 4 Stroke	HC5358-3	HO6003	H06002	Req. 2 x Spacer Kit H05090 Fig. 28e

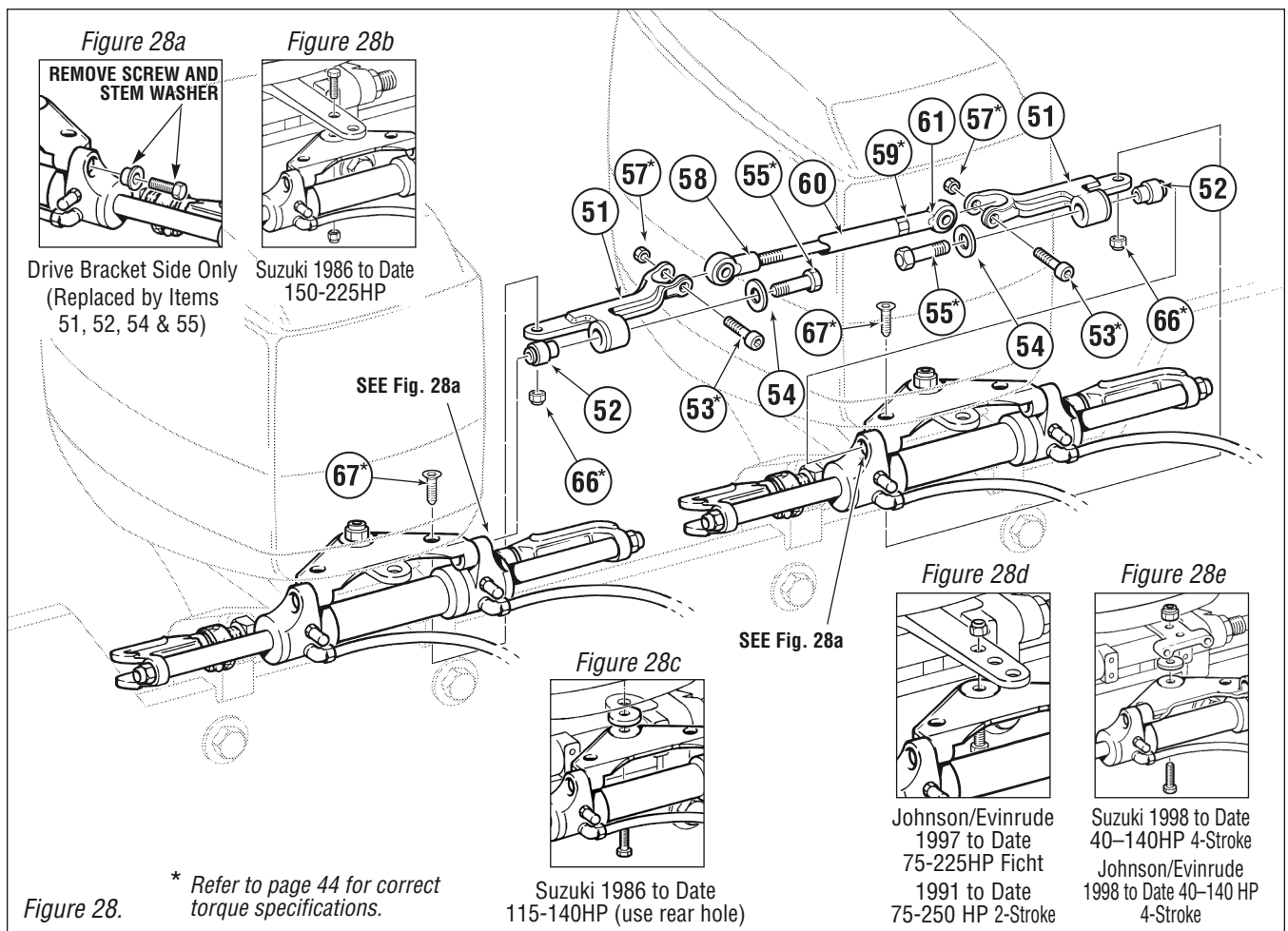

ITEM	PART #	QTY	DESCRIPTION
51	961665	2	Drive Bracket Assembly
52	961686	2	Spacer
*53	186540	2	Shoulder Bolt, 3/8" x 1-1/4", SS
54	010924	2	Washer 5/16" x 3/4" OD SS
*55	961704	2	HHCS 5/16" NC x 2-1/2" SS
*57	704525	2	Nut, Nylok®, 5/16" NC, SS

ITEM	PART #	QTY	DESCRIPTION
58	722543	1	tie bar c/w Ball Joint
*59	192126	1	Nut, Nylok® 1/2" NF, NI PL BR
60	722753	1	Stringer Tube, SS
61	116527	1	Rod End Ball 1/2" SS
*66	113021	2	Nut, Nylok®, 5/16" NC, SS, Thin
*67	185901	2	FHSCS, 5/16" NC x 3/4", SS

INSTALLATION INSTRUCTIONS

TWIN ENGINES

⚠ WARNING The steering equipment noted below is for use in boats that are used in a 'normal' fashion. For ALL performance orientated, or, any boat that is rigged with engines that exceed 300HP per engine, SeaStar Solutions recommends the use of the Tournament Type Steering Cylinders and Tie bars. If you have any questions in regards to your installation, please contact SeaStar Solutions. Refer to page 44 for correct torque specifications of all installation hardware.

H06002-Dual Cylinder Tie Bar Kit

ENGINE MANUFACTURER	YEAR	MODEL	CYLINDER	ENGINE TIE BAR KITS		NOTES
				SINGLE CYL.	DUAL CYL.	
YAMAHA	1998 TO 2007	40-90 HP 2 Stroke	HC5345-3	H06001	H06002	Engine clamp brackets must be modified (cut or ground) and the engine through bolted onto transom or interference will occur restricting engine trim and tilt. Requires spacer kit H05090. (See Fig. 29b).
	2007 TO DATE	25-75 HP	HC5348-3	H06001	H06002	Requires Spacer Kit H05090.

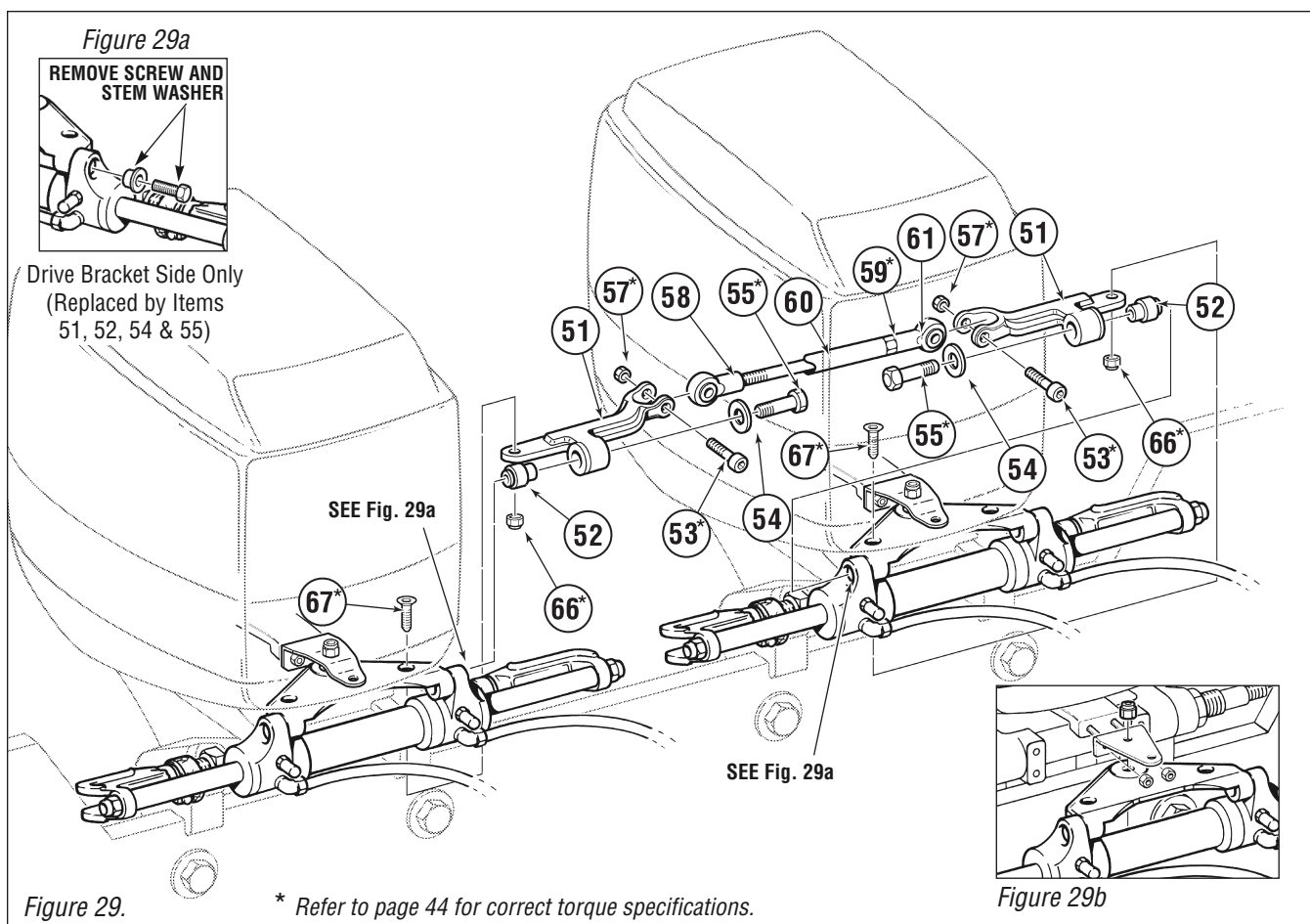

Figure 29.

* Refer to page 44 for correct torque specifications.

Figure 29b

ITEM	PART #	QTY	DESCRIPTION
51	961665	2	Drive Bracket Assembly
52	961686	2	Spacer
*53	186540	2	Shoulder Bolt, 3/8" x 1-1/4", SS
54	010924	2	Washer 5/16" x 3/4" OD SS
*55	961704	2	HHCS 5/16" NC x 2-1/2" SS
*57	704525	2	Nut, Nylok®, 5/16" NC, SS

ITEM	PART #	QTY	DESCRIPTION
58	722543	1	tie bar c/w Ball Joint
*59	192126	1	Nut, Nylok® 1/2" NF, NI PL BR
60	722753	1	Stringer Tube, SS
61	116527	1	Rod End Ball 1/2" SS
*66	113021	2	Nut, Nylok®, 5/16" NC, SS, Thin
*67	185901	2	FHSCS, 5/16" NC x 3/4", SS

▲ WARNING The steering equipment noted below is for use in boats that are used in a 'normal' fashion. For ALL performance orientated, or, any boat that is rigged with engines that exceed 300HP per engine, SeaStar Solutions recommends the use of the Tournament Type Steering Cylinders and Tie bars. If you have any questions in regards to your installation, please contact SeaStar Solutions. Refer to page 44 for correct torque specifications of all installation hardware.

INSTALLATION INSTRUCTIONS

TWIN ENGINES

H06002-Dual Cylinder Tie Bar Kit

ENGINE MANUFACTURER	YEAR	MODEL	CYLINDER	ENGINE TIE BAR KITS		NOTES
				SINGLE CYL.	DUAL CYL.	
YAMAHA	1986 TO 2004	75-300 HP (2 & 4 Stroke)	HC5358-3	H06001	H06002	See Fig 30b Must use Tournament Cylinders.
	2004 TO DATE	3.3L 75-300 HP	HC5358-3	H06001	H06002	
	2006 TO DATE	4.2L 75-300 HP	HC5345-3	H06001	H06002	
	2007 TO DATE	350 HP	N/A	N/A	N/A	
MERCURY/MARINER	2002-TO DATE	225 HP (4 Stroke)	HC5358-3	H06001	H06002	

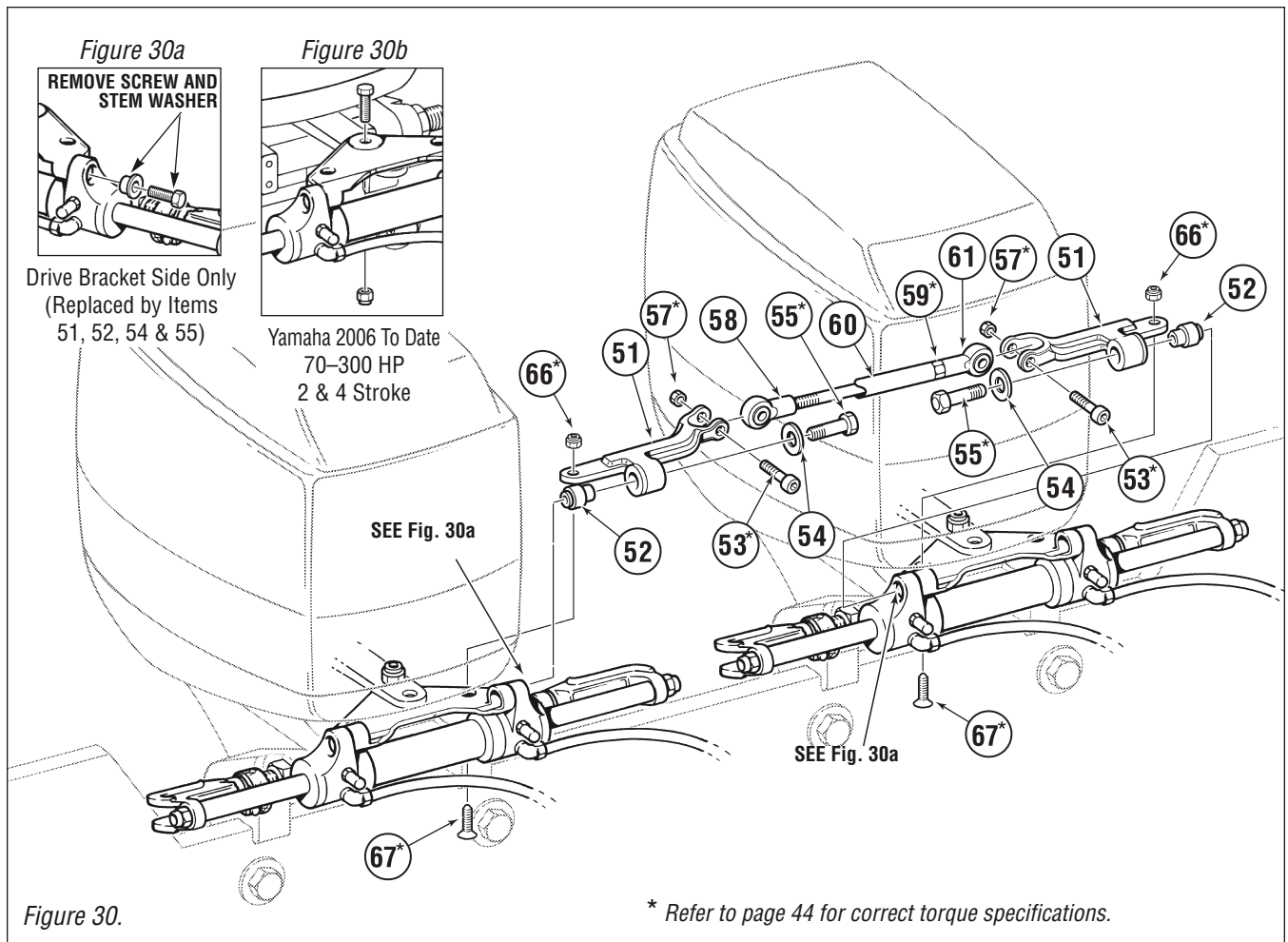

ITEM	PART #	QTY	DESCRIPTION
51	961665	2	Drive Bracket Assembly
52	961686	2	Spacer
*53	186540	2	Shoulder Bolt, 3/8" x 1-1/4", SS
54	010924	2	Washer 5/16" x 3/4" OD SS
*55	961704	2	HHCS 5/16" NC x 2-1/2" SS
*57	704525	2	Nut, Nylok®, 5/16" NC, SS

ITEM	PART #	QTY	DESCRIPTION
58	722543	1	Tiebar c/w Ball Joint
*59	192126	1	Nut, Nylok® 1/2" NF, NI PL BR
60	722753	1	Stringer Tube, SS
61	116527	1	Rod End Ball 1/2" SS
*66	113021	2	Nut, Nylok®, 5/16" NC, SS, Thin
*67	185901	2	FHSCS, 5/16" NC x 3/4", SS

INSTALLATION INSTRUCTIONS

TWIN ENGINES

⚠ WARNING The steering equipment noted below is for use in boats that are used in a 'normal' fashion. For ALL performance orientated, or, any boat that is rigged with engines that exceed 300HP per engine, SeaStar Solutions recommends the use of the Tournament Type Steering Cylinders and Tie bars. If you have any questions in regards to your installation, please contact SeaStar Solutions. Refer to page 44 for correct torque specifications of all installation hardware.

HO6002-Dual Cylinder Tie Bar Kit for HC5348-3 Cylinder Installation **ONLY**

ENGINE MANUFACTURER	YEAR	MODEL	CYLINDER	ENGINE TIE BAR KITS		NOTES
				SINGLE CYL.	DUAL CYL.	
JOHNSON EVINRUDE	1977 TO 1990	65-300 HP	HC5348-3	HO6001	HO6002	

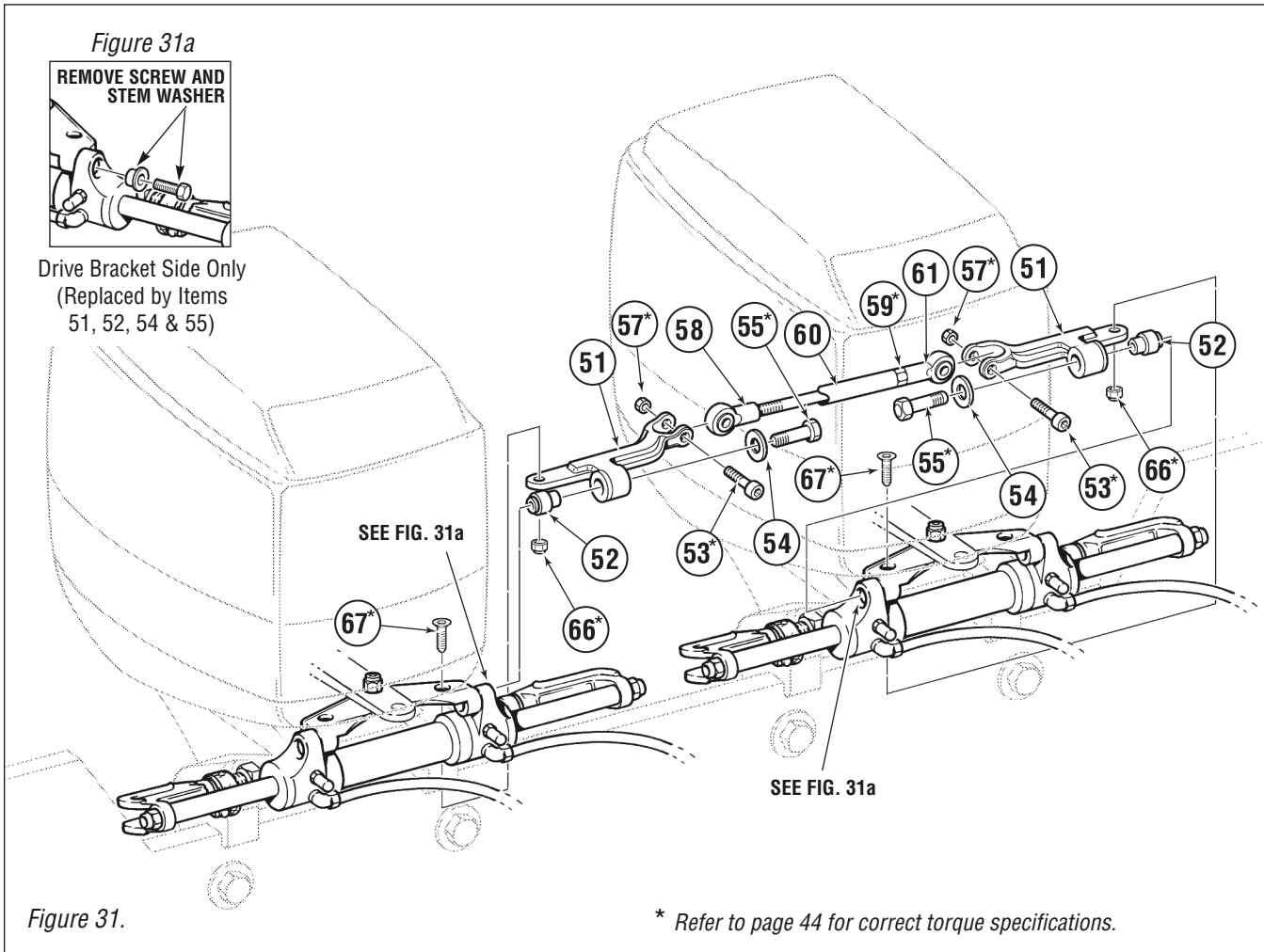

ITEM	PART #	QTY	DESCRIPTION
51	961665	2	Drive Bracket Assembly
52	961686	2	Spacer
*53	186540	2	Shoulder Bolt, 3/8" x 1-1/4", SS
54	010924	2	Washer 5/16" x 3/4" OD SS
*55	961704	2	HHCS 5/16" NC x 2-1/2" SS
*57	704525	2	Nut, Nylok®, 5/16" NC, SS
58	722543	1	Tiebar c/w Ball Joint
*59	192126	1	Nut, Nylok® 1/2" NF, NI PL BR

ITEM	PART #	QTY	DESCRIPTION
60	722753	1	Stringer Tube, SS
61	116527	1	Rod End Ball 1/2" SS
*66	113021	2	Nut, Nylok®, 5/16" NC, SS, Thin
*67	960516	2	FHCS, 5/16" NC x 1", SS

▲ WARNING The steering equipment noted below is for use in boats that are used in a 'normal' fashion. For ALL performance orientated, or, any boat that is rigged with engines that exceed 300HP per engine, SeaStar Solutions recommends the use of the Tournament Type Steering Cylinders and Tie bars. If you have any questions in regards to your installation, please contact SeaStar Solutions. Refer to page 44 for correct torque specifications of all installation hardware.

INSTALLATION INSTRUCTIONS

TWIN ENGINES

H06003-Single Cylinder Tie Bar Kit, Johnson/Evinrude, Suzuki

ENGINE MANUFACTURER	YEAR	MODEL	CYLINDER	ENGINE TIE BAR KITS		NOTES
				SINGLE CYL	DUAL CYL	
JOHNSON/EVINRUDE	1977 TO 1990	65-300 HP	HC5348-3	H06003	H06002	See Fig. 32d Includes ETech
	1991 TO DATE	40-250 HP	HC5345-3	H06003	H06002	
	1996 TO DATE	75-250 HP FIGHT	HC5345-3	H06003	H06002	
	1998 TO DATE	40-140 HP 4 Stroke	HC5358-3	H06003	H06002	*Req. 2 x H05090. See Fig. 32b & 32c 3.4L V6 250H.O.-300HP
	2007 TO DATE	3.3L V6 200-250 HP	HC5345-3	H06003	H06002	
SUZUKI	1986 TO DATE	150-300 HP	HC5345-3	H06003	H06002	*Req. 2 x H05090. See Fig. 32b & 32c *Req. 2 x H05090. See Fig. 32b & 32c
	1998 TO DATE	60-70 HP	HC5345-3	H06003	H06002	
	1998 TO DATE	40-140 HP 4 Stroke	HC5358-3	H06003	H06002	

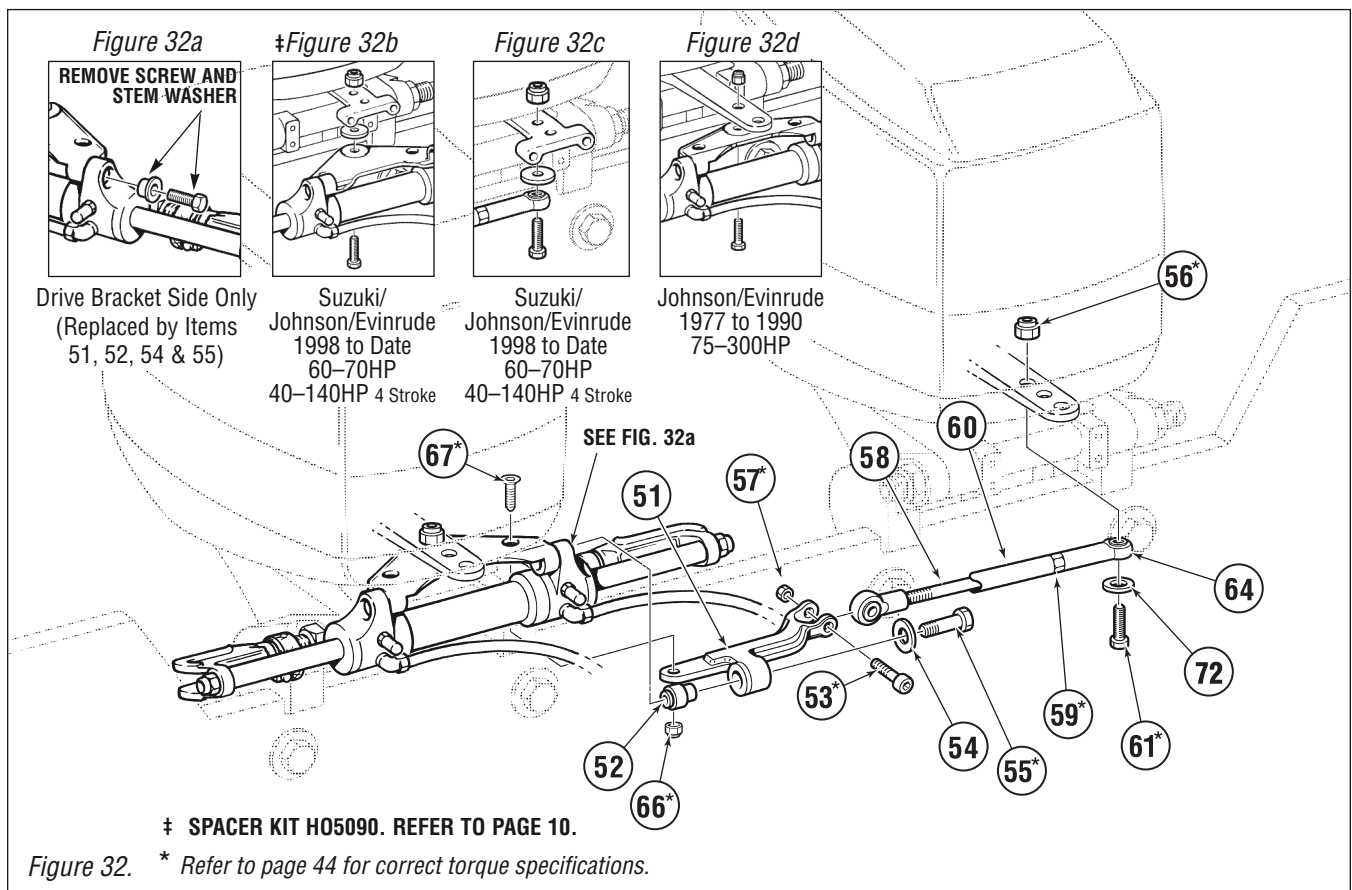

ITEM	PART #	QTY	DESCRIPTION
51	961665	1	Drive Bracket Assembly
52	961686	1	Spacer
*53	186540	1	Shoulder Bolt, 3/8" x 1-1/4", SS
54	010924	1	Washer 5/16" Flat 3/4", SS
*55	961704	1	HHCS 5/16" NC x 2-1/2", SS
*56	113529	1	Nut, Nylok®, 3/8" NF, SS
*57	704525	1	Nut, Nylok®, 5/16" NC, SS
58	722545	1	Tie Bar c/w Ball Joint (H06003)

ITEM	PART #	QTY	DESCRIPTION
*59	192126	1	Nut, Nylok® 1/2" NF, NI PL BR
60	722755	1	Stringer Tube
*61	116320	1	HHCS, 3/8" NF x 1-1/2", SS
64	116527	1	Rod End SS 1/2" NF
*65	113529	1	Nut, Nylok®, 3/8" NF, SS
*66	113021	1	Nut, Nylok®, 5/16" NC, SS, Thin
*67	185901	1	FHSCS, 5/16" NC x 3/4", SS
72	113622	1	Washer, 3/8" Dia., SS

INSTALLATION INSTRUCTIONS

TWIN ENGINES

⚠ WARNING The steering equipment noted below is for use in boats that are used in a 'normal' fashion. For ALL performance orientated, or, any boat that is rigged with engines that exceed 300HP per engine, SeaStar Solutions recommends the use of the Tournament Type Steering Cylinders and Tie bars. If you have any questions in regards to your installation, please contact SeaStar Solutions. Refer to page 44 for correct torque specifications of all installation hardware.

H06003-Single Cylinder Tie Bar Kit, Mercury

ENGINE MANUFACTURER	YEAR	MODEL	CYLINDER	ENGINE TIE BAR KITS		NOTES
				SINGLE CYL.	DUAL CYL.	
MERCURY	1998-TO DATE	40, 50 & 60 HP 2 & 4 Stroke	HC5345-3	H06003	H06002	Requires Kit H05090
HONDA	2001-TO DATE 2010 TO DATE	150 HP 4 Stroke 115-150 HP	HC5345-3 HC5345-3	H06003 H06003	H06002 H06002	See Fig. 33c & 33d

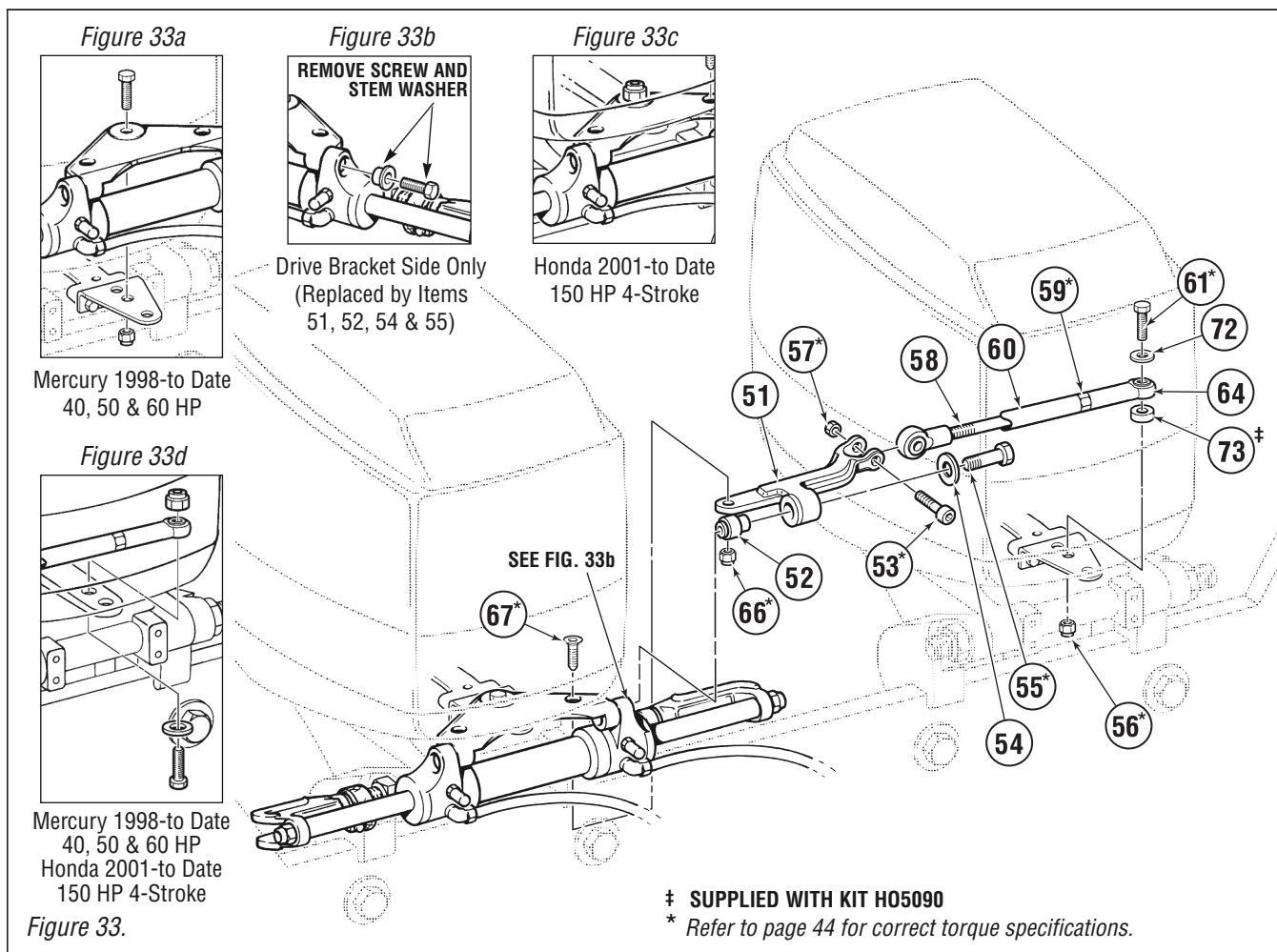

ITEM	PART #	QTY	DESCRIPTION
51	961665	1	Drive Bracket Assembly
52	961686	1	Spacer
*53	186540	1	Shoulder Bolt, 3/8" x 1-1/4", SS
54	010924	1	Washer 5/16" Flat 3/4", SS
*55	961704	1	HHCS 5/16" NC x 2-1/2", SS
*56	113529	1	Nut, Nylok®, 3/8" NF, SS
*57	704525	1	Nut, Nylok®, 5/16" NC, SS
58	722545	1	Tie Bar c/w Ball Joint (H06003)
*59	192126	1	Nut, Nylok® 1/2" NF, NI PL BR

ITEM	PART #	QTY	DESCRIPTION
60	722755	1	Stringer Tube
*61	116320	1	HHCS, 3/8" NF x 1-1/2", SS
64	116527	1	Rod End SS 1/2" NF
*65	113529	1	Nut, Nylok®, 3/8" NF, SS
*66	113021	1	Nut, Nylok®, 5/16" NC, SS, Thin
*67	185901	1	FHSCS, 5/16" NC x 3/4", SS
72	113622	1	Washer, 3/8" Dia., SS
‡73	710921	1	1/8" SS Spacer

▲ WARNING The steering equipment noted below is for use in boats that are used in a 'normal' fashion. For ALL performance orientated, or, any boat that is rigged with engines that exceed 300HP per engine, SeaStar Solutions recommends the use of the Tournament Type Steering Cylinders and Tie bars. If you have any questions in regards to your installation, please contact SeaStar Solutions. Refer to page 44 for correct torque specifications of all installation hardware.

INSTALLATION INSTRUCTIONS

TWIN ENGINES

H06003-Single Cylinder Tie Bar Kit, Yamaha

ENGINE MANUFACTURER	YEAR	MODEL	CYLINDER	ENGINE TIE BAR KITS		NOTES
				SINGLE CYL	DUAL CYL	
YAMAHA	1998 TO DATE	40-50 HP	HC5345-3	H06003	H06002	See Fig. 34e
	1998 TO DATE	60 HP	HC5345-3	H06003	H06002	Req. 2 x Spacer Kit H05090. See Fig. 34e
	1998 TO DATE	70-90 HP	HC5345-3	H06003	H06002	Req. 2 x Spacer Kit H05090.
	1998 TO DATE	80-100 HP	HC5345-3	H06003	H06002	See Fig. 34b
	1998 TO DATE	115 HP 4 Stroke	HC5358-3	H06003	H06002	See Fig. 34c
	2002 TO DATE	40-60HP 4 Stroke	HC5348-3	H06003	H06002	Req. 2 x Spacer Kit H05090. See Fig. 34d

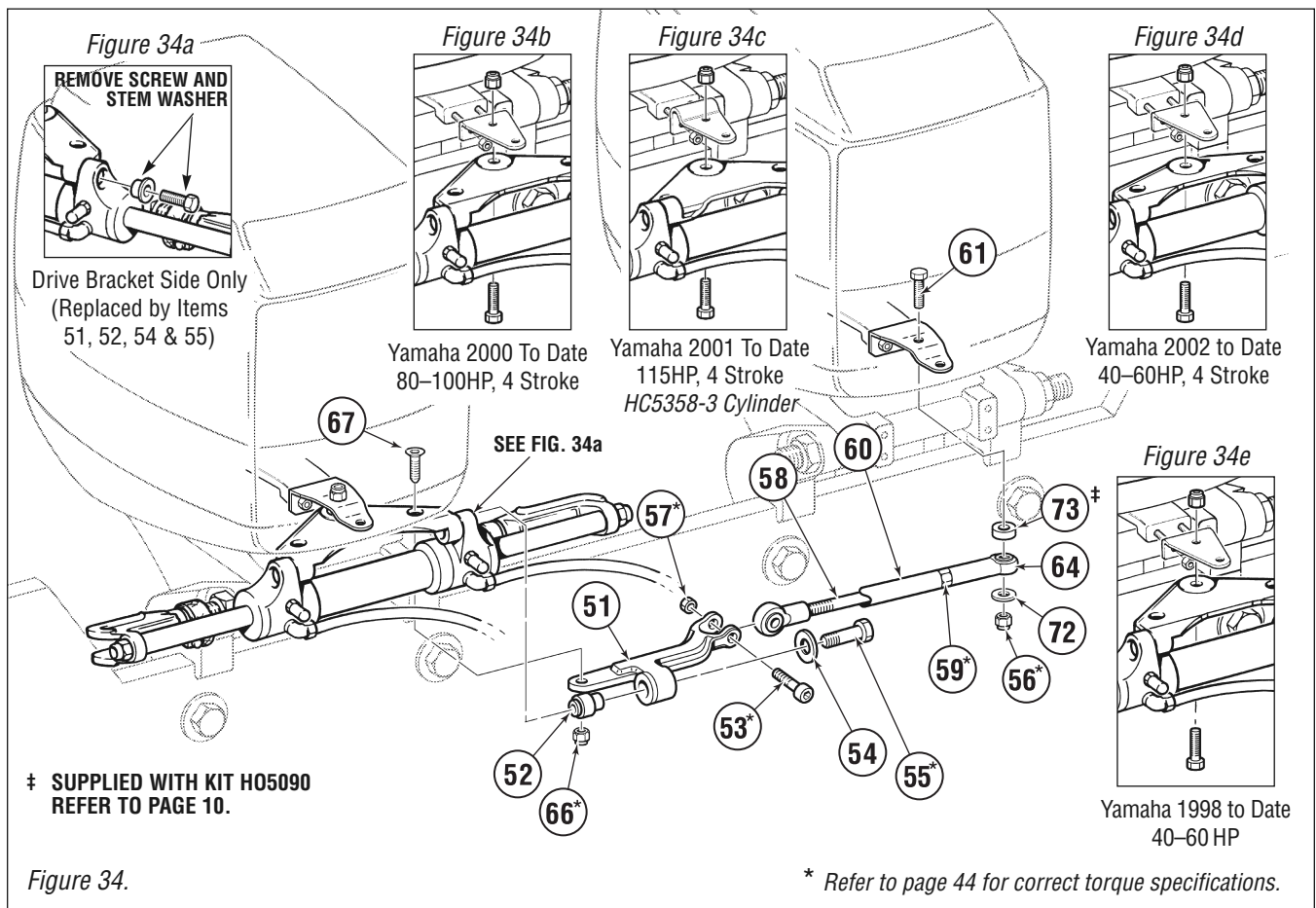

ITEM	PART #	QTY	DESCRIPTION
51	961665	1	Drive Bracket Assembly
52	961686	1	Spacer
*53	186540	1	Shoulder Bolt, 3/8" x 1-1/4", SS
54	010924	1	Washer 5/16" Flat 3/4", SS
*55	961704	1	HHCS 5/16" NC x 2-1/2", SS
*56	113529	1	Nut, Nylok®, 3/8" NF, SS
*57	704525	1	Nut, Nylok®, 5/16" NC, SS
58	722545	1	Tie Bar c/w Ball Joint (H06003)
*59	192126	1	Nut, Nylok® 1/2" NF, NI PL BR

ITEM	PART #	QTY	DESCRIPTION
60	722755	1	Stringer Tube
*61	116320	1	HHCS, 3/8" NF x 1-1/2", SS
64	116527	1	Rod End SS 1/2" NF
*65	113529	1	Nut, Nylok®, 3/8" NF, SS
*66	113021	1	Nut, Nylok®, 5/16" NC, SS, Thin
*67	185901	1	FHSCS, 5/16" NC x 3/4", SS
72	113622	1	Washer, 3/8" Dia., SS
†73	710921	1	1/8" SS Spacer
†74	773421	1	Spacer (For use with 90HP only)

INSTALLATION INSTRUCTIONS

TWIN ENGINES

WARNING Refer to page 44 for correct torque specifications of all installation hardware.

NOTICE SeaStar Solutions is no longer manufacturing engine extension plates for any engine built after 2004. Please see pages 14-33 for cylinder and tiebar part numbers.

For HC5347-3 Cylinder Installation ONLY

ENGINE MANUFACTURER	YEAR	MODEL	CYLINDER	ENGINE ADAPTER PLATES			NOTES
				SINGLE	TWIN c/w tie-rod	TWIN w/o tie rod	
HONDA	1998 TO 2010	115-130 HP	HC5347-3	NOT REQ.	H05063	H05064	

Figure 35.

NOTICE
Port Installation Only

WARNING
Cylinder interference may occur if installed on transom exceeding Maximum recommended Transom Thickness 2-3/4" causing property damage and or personal injury.

WARNING
The top corners of the Tab Washer (item 54) must be folded against the flats of the Hex Bolt after bolts are tightened.

WARNING
If interference occurs between hose elbow or tee fitting, SeaStar Solutions recommends:
1. Remove the fitting from the cylinder body.
2. Clean threads of fitting and re-apply Loctite® with PST. Thread the fitting back into the port and refer to page 44 for correct torque specifications. Adjust fitting to desired angle.
If interference re-occurs please contact SeaStar Solutions (ref. rear cover for contact info.).
* Refer to page 44 for correct torque specifications.

WARNING
Fully tilting or independent tilting of the engine/engines may cause the steering cylinder to interfere with the transom and/or splashwell. Possible damage to the steering system can result. Ensure that the cylinder is free from interference at all times. Maximum Transom thickness 2-3/4"

ITEM	PART #	QTY	DESCRIPTION
51	688725	2	Extension Plate
*52	113529	2	Nut 3/8" NF Nylok®
53	113622	4	Washer 3/8" dia.
54	823673	4	Locking Tab Washer
*55	752930	4	Screw M10 x 1.25 x 62mm HHCS
*56	688726	2	Screw 3/8" NF x 2-1/4" HHCS, SS
57	722721	1	Stringer Tube

ITEM	PART #	QTY	DESCRIPTION
58	722523	1	Threaded Rod c/w Ball Joint
59	192126	1	Nut 1/2" NF Nylok®
61	116527	2	Ball Joint
62	710921	2	Spacer

FILLING AND PURGING THE SYSTEM

Read First

NOTICE

If system is fitted with SeaStar Power Assist, please refer to your Power Assist Installation Manual for bleeding instructions.

These instructions show how to fill and purge a Single Station Front Mount Cylinder System. For twin station and/or twin cylinder filling and purging instructions refer to instructions on page 39 first and then proceed with instructions on this page.

This procedure requires two people. One person may not be able to remove all the air from the system which will result in spongy, unresponsive steering.

During the entire filling procedure, oil **must** be visible in the filler tube. **DO NOT** allow the oil level to disappear into the helm pump, as this may introduce air into the system and increase your filling time.

NOTICE

If using a Liquid Tie bar Valve, part # HA5471-2, please refer to the bleeding instructions included with the liquid tie bar valve.

Hydraulic Oil Requirements

2 bottles (2 quarts or liters) for single station and single cylinder systems.
1 additional bottle for each additional helm, cylinder, or auto pilot.

NOTICE

Oil can be re-used if filtered through a fine mesh screen such as used for gasoline. If unable to filter oil, an additional bottle of oil is required.

NOTICE

"Bleeder" may refer to cylinders fitted with bleed tee fittings or bleed screws. If fitted with bleed tee fitting, open bleeder by unscrewing bleed nipple nut two turns.

NOTICE

Filling the helm full of oil can be done faster if oil is poured into the helm prior to connecting filler tube and oil bottle to the helm. Part # HA5438.

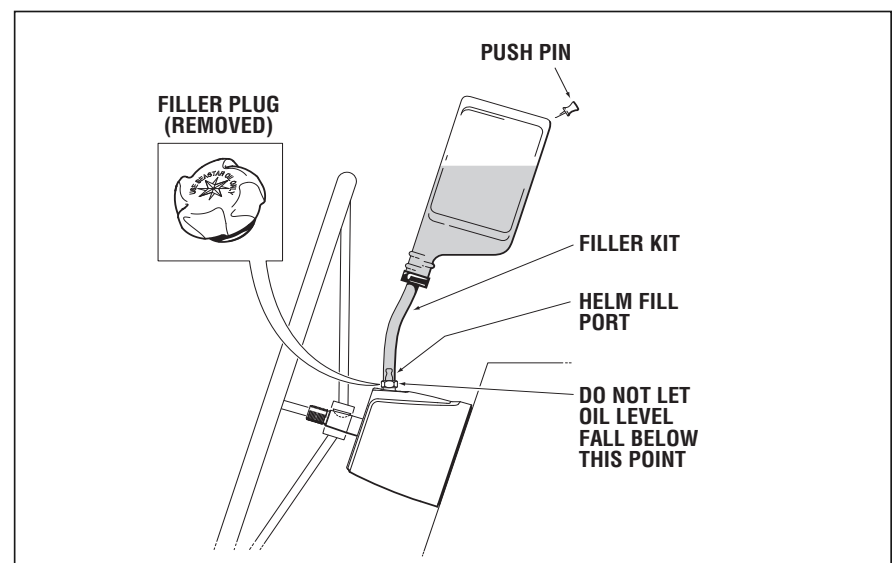

Figure 36.

NOTICE

In the following pages you are instructed to hold cylinder body with your hand, if the cylinder is mounted to an engine, use the engine to hold the body in position.

HYDRAULIC STEERING

FILLING AND PURGING

Hydraulic Fluid

Recommended oils for your steering system are:

- SeaStar Hydraulic Fluid, part no. HA5430 (1 quart), HA5440 (1 Gal.)
- Texaco H015
- Aero Shell Fluid #41
- Esso Univis N15
- Chevron Aviation Fluid A
- Mobil Aero HFA
- Fluids meeting Mil H5606 specifications.
- Automatic transmission fluid Dexron II may be used in an emergency.

⚠ CAUTION

Never use brake fluid. Any non-approved fluid may cause irreparable damage, loss of steering, and cancellation of warranty.

In cases of extreme emergency any non-toxic, non-flammable fluid may provide temporary steering.

Fill Plugs for SeaStar Helms

VENT PLUG - Part No. HA5431

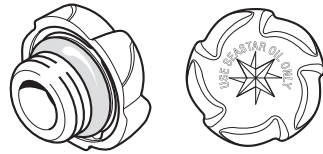

SUPPLIED WITH SEASTAR HELM PUMP

- MUST BE USED WITH HELM PUMP ON ALL SINGLE STEERING STATION SYSTEMS.
- MUST BE USED ON UPPERMOST HELM PUMP ON MULTI STEERING STATION SYSTEMS.

NON-VENT PLUG - Part No. HA5432

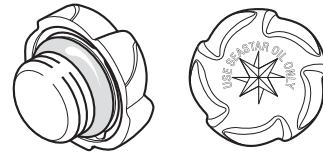

- MUST BE USED ON ALL HELM PUMPS OTHER THAN UPPERMOST HELM PUMP ON MULTI STEERING STATION SYSTEMS.
- THIS NON-VENT PLUG IS SUPPLIED WITH ADDITIONAL STATION FITTING KIT NO. HF5501 AND HF5502.

Figure 37.

Single Station One Cylinder

Step 1

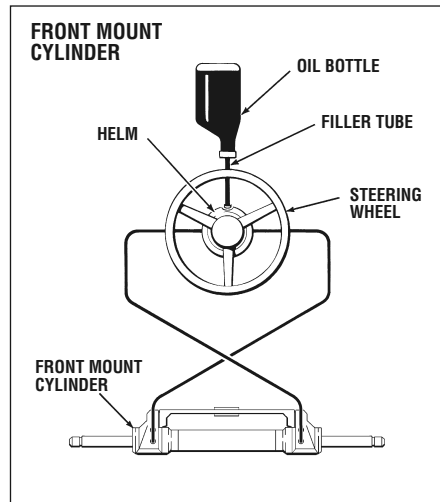

- Screw the threaded end of the filler tube into the helm filler port.
- Remove the cap from the oil bottle and holding upright screw into the filler tube bottle cap. Poke hole in the bottom of the bottle.
- Fill the helm pump full of hydraulic oil so that it is visible in the filler tube. Oil should always be visible in the filler tube. Use the next bottle of fluid at any time during the procedure in order to maintain the oil level. **DO NOT** proceed with step two until helm is full.

Step 2

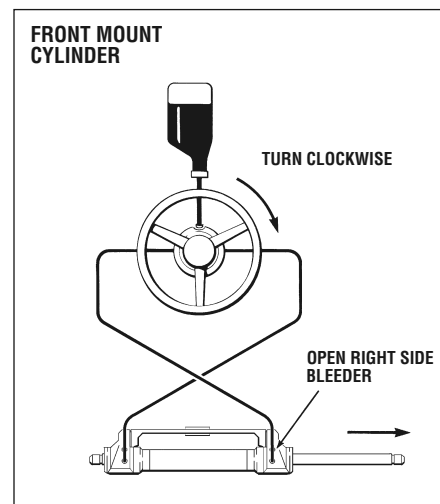

- Turn the steering wheel clockwise until the cylinder rod is fully extended on the right side of the cylinder.
- Open right side bleeder.

Step 3

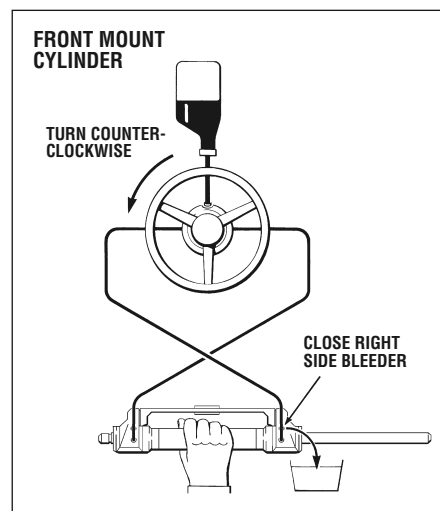

- Holding the cylinder body (Front Mount cylinder) or rod (Side Mount cylinder) to prevent the body/rod from moving, turn the steering wheel counter-clockwise until a steady stream of air free oil comes out of the bleeder. (Drain approx. 1/2 bottle of oil or as required).
DO NOT use anything other than your hands to restrain the cylinder body/rod.
- While continuing to turn the wheel close the right side bleeder and let go of the cylinder body/rod.

HYDRAULIC STEERING

FILLING AND PURGING

Step 4

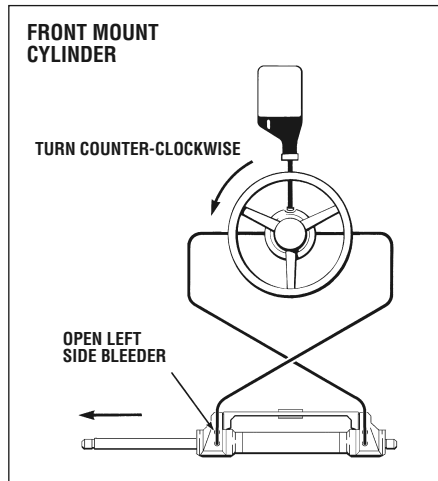

- Continue turning the steering wheel counter-clockwise until the cylinder rod is fully extended to the left. (Steering wheel will come to a stop).
- Open the left bleeder.

Step 5

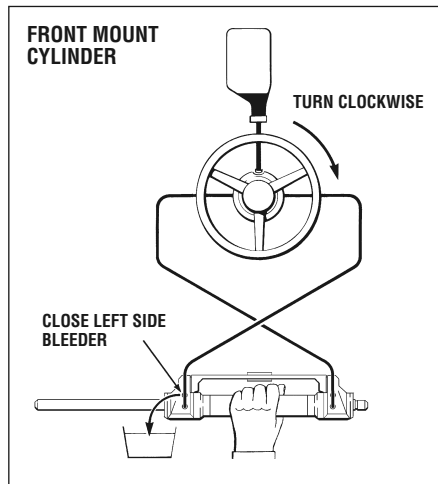

- Holding the cylinder body (Front Mount cylinder) or rod (Side Mount cylinder) to prevent the body/rod from moving, turn the steering wheel clockwise until a steady stream of air free oil comes out of the bleeder.
- While continuing to turn the wheel close the left side bleeder and let go of the cylinder body/rod.

⚠ CAUTION

Prior to operating system, perform Oil Level System Check, refer to page 40.

Number of Steering Wheel Turns

When steering system has been properly bled, steering wheel turns from hard over to hard over will be as shown in the chart.

Helm Displacement	Single Cylinder	Twin Cylinder with Mechanical Tiebar	Twin Cylinder with Liquid Tiebar
1.4	5.90	11.8	5.90
1.7	4.90	9.76	4.90
2.0	4.15	8.30	4.15
2.4	3.45	6.90	3.45
3.0	2.76	5.50	2.76

Twin Station Single Cylinder

Perform steps 1 through 5 at station no. 1. Then repeat steps 1-5 at station no. 2.

Oil requirements 4-5 bottles.

Note: Refer to Oil Level and System Check page 40.

When properly bled, steering wheel turns will be as shown in the chart.

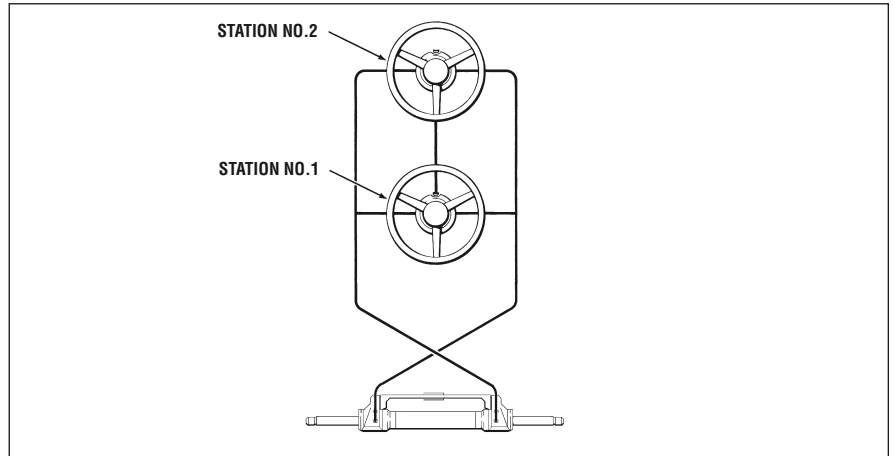

Single Station Twin Cylinder

When performing steps 1 through 5, perform instructions in each step first on cylinder no. 1 and then on cylinder no. 2, before proceeding to the next step. ie: Perform instructions referring to right side of cylinder first on cylinder no. 1 and then on cylinder no. 2.

Oil requirements 4-5 bottles.

Note: Refer to Oil Level and System Check on page 40. Steering wheel turns will be as shown in the chart.

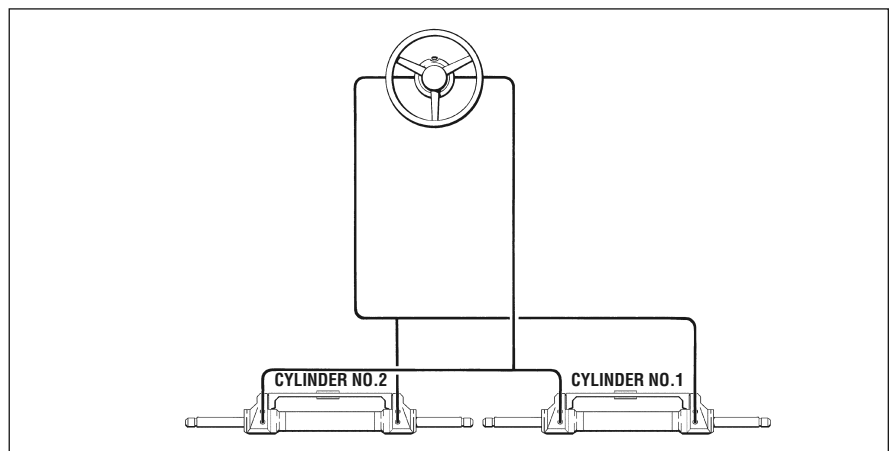

Twin Station Twin Cylinder

Follow same procedure as instructed for single station-twin cylinders, beginning at station no. 1, and repeat entire procedure at station no. 2.

Note: When properly bled, steering wheel turns will be as shown in the chart.

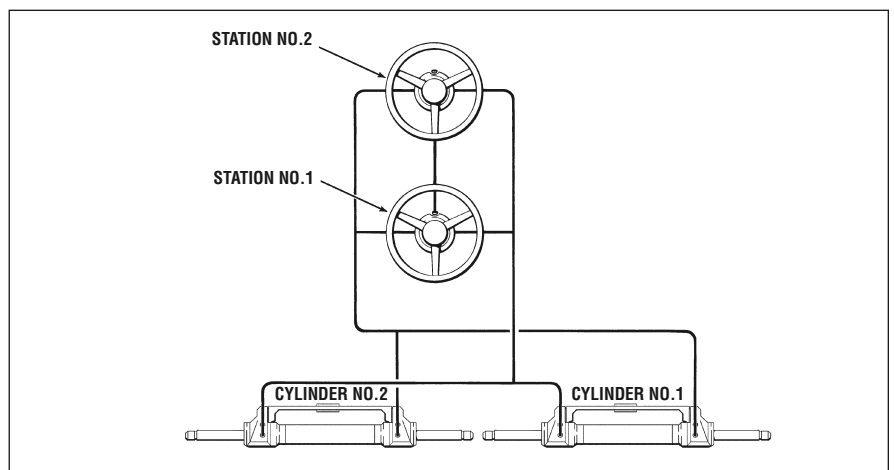

Oil Level and System Check

Step 1 – Oil level Setting

⚠ WARNING The oil level **MUST** be checked and maintained **BEFORE** EACH use to ensure safe steering operation. Failure to adhere to this warning may lead to loss of steering control resulting in persons being ejected from vessel or collision with an obstacle, leading to property damage, personal injury and/or death.

- For helms mounted with the wheel shaft completely horizontal **MUST** be filled to the bottom of filler hole **AT ALL TIMES**. **DO NOT** allow oil level to drop more than 1/4" below filler threads.
- For helms mounted on a 20 degree angle, or, with wheel shaft in the vertical position, oil level should be within 1/2" from the bottom of the filler hole.

NOTICE

*If the helm is overfilled fluid **WILL** leak out of the vent cap.*

Step 2 – System Check

⚠ WARNING The system check **MUST** be completed after installation. Doing so will ensure the safe operation of your steering system and will any fault/leak will show at this time. Failure to adhere to this warning/check may result in the loss of steering control leading to ejection from the vessel, or, collision with an obstacle resulting in property damage, personal injury and/or death.

- Turn steering wheel hard over to hard over to confirm unrestricted movement of the steering system and hoses. Repeat this procedure in ALL trim/tilt positions of the engine(s). If interference occurs, or, hoses are being stretched this **MUST** be removed prior to operating your boat.
- Confirm that engine(s) are deflecting to the proper direction when steering wheel is turned.
- If no interference is noticed, or, any interference is corrected, go to next step.
- Take steering wheel hard over to starboard (any helm can be used on a multi-station boat). Once the wheel reaches its stop point (cylinder is fully stroked out), continue to force the wheel one (1) full turn past stop. Leave wheel in this position while you check all PORT side connections, fittings, seals and hoses for leaks.

NOTICE *This step will NOT harm the system and any noise made during this step should not be considered a fault in the steering system.*

- If leaks are noticed they **MUST** be repaired prior to operating boat. After repair repeat bleeding procedures as outlined in this manual
- Repeat to the Port direction and inspect ALL starboard side connections, fittings, seals and hoses for leaks.

NOTICE *This step will NOT harm the system and any noise made during this step should not be considered a fault in the steering system.*

- If leaks are noticed they **MUST** be repaired prior to operating boat. After repair repeat bleeding procedures as outlined in this manual.

⚠ WARNING

Failure to complete the above noted step or, failure to correct a problem may result in loss of steering control leading to ejection from the vessel or collision with an obstacle resulting in property damage, personal injury and/or death.

ROUTINE MAINTENANCE

! WARNING

Following the routine maintenance schedules as outlined below, in the time frame noted will ensure years of service from your SeaStar Steering System, as well as keep you and your passengers safe from the dangers that are present on and off the water.

1. Owner(s) (End Users)

Prior to every use.

1. Check Fluid level in highest helm pump (see page 35 for proper fluid level setting).
2. Verify immediate steering response when turning steering wheel(s). (Ensure engine turns when steering wheel is turned.)
3. Visually inspect all steering hoses and fittings for wear, kinking and/or leaks.
4. Check for binding, loose, worn or leaking steering components.

! WARNING

DO NOT operate boat if any component is not in proper working condition.

2. Qualified Marine Mechanic

After first 20 hours, then every 100 hours or 6 months thereafter (which ever comes first).

1. All points noted above.
2. Check tightness of ALL fasteners/fittings throughout the steering system. Tighten to correct torque specifications as required.
3. Check for mechanical play or slop throughout steering system, correct as required.
4. Check for signs of corrosion. If corrosion is present contact your dealer or SeaStar Solutions.

After every 200 hours or 12 months (which ever comes first).

1. All points noted above.
2. Remove support rod from engine steering/tilt tube. Clean engine steering/ tilt tube and re-grease using a good quality marine grease.
3. Grease support rod liberally
4. Grease all contact points shown in Figure 38. DO NOT remove tiller bolt to re-grease.
5. Remove steering wheel and re-grease wheel shaft using a good quality marine grease.
6. Inspect hydraulic oil for cleanliness, flush if required.

! WARNING

Any work being performed with the steering system **MUST** be completed by a qualified mechanic with the working knowledge of the system.

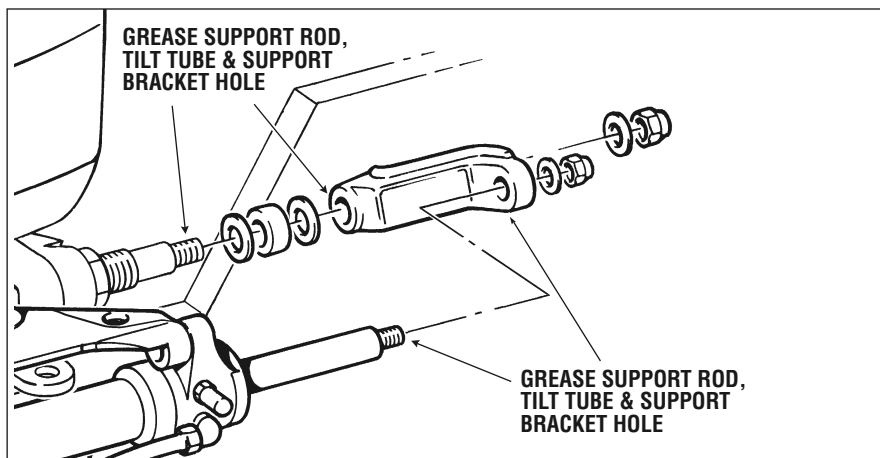

Figure 38.

TROUBLESHOOTING GUIDE

If properly installed and maintained, your SeaStar Steering System will provide years of safe and reliable performance. Our systems have been designed with protection against over-pressure situations by a pressure relief valve. Most faults occur when installation instructions have not been followed and in most cases will present themselves immediately upon filling the system. Below are the most common faults and their likely cause and solution. Extreme caution must be exercised when diagnosing and correcting a fault. These troubleshooting guides may seem simple in text, however these **MUST** be completed by a qualified marine mechanic that has working knowledge of the steering system.

WARNING

SeaStar Solutions does NOT recommend disassembly of a helm pump, or, removing a steering cylinder rod/shaft at any time. Doing so may cause more damage, leading to irreparable damage and costly replacements.

FAULT	CAUSE	SOLUTION
<p>1. During filling, helm becomes completely locked up.</p>	<ul style="list-style-type: none"> Mechanical interference with other components. Blockage in the steering lines. Tilting mechanism not installed properly. Engine(s) are restricted. Power Assist H1, or H2 line crossed with R line. 	<ul style="list-style-type: none"> Check ALL areas for interference, correct as required. Remove all steering lines. Blow air through lines. Any line not allowing good air flow may should be replaced. Confirm tilt mechanism is installed correctly. Confirm that engines are able to be moved freely with cylinder not connected. Confirm system is plumbed correctly.
<p>2. System is very difficult to fill, air keeps burping out top of helm, even after system appears full.</p>	<ul style="list-style-type: none"> Air remaining in system. Bleed fitting leaking. Coiled hose. Reservoir/compensating lines not purged free of air. 	<ul style="list-style-type: none"> Bleed steering system again utilizing bleeder fittings fitted on the steering cylinder. Tighten bleeder, replace if leak continues. DO NOT cut hoses. Lessen coil, or, replace with shorter lines. Bleed air from reservoir/compensating lines.
<p>3. Steering is hard to turn even when boat is not moving and engines are OFF.</p>	<ul style="list-style-type: none"> Adjusting nut on support rod is over tightened. Restrictions on hoses (see Fault 1). Mechanical interference with other components (see Fault 1). Air in system (yes, air will lead to heavy steering). Incorrect fluid has been used to fill system. 	<ul style="list-style-type: none"> Nut should be hand-tight. See fault 1. See fault 1. Bleed Steering System. Drain and flush, fill and bleed with SeaStar fluid.

3. Continued.

Steering is hard to turn even when boat is not moving and engines are OFF.

- Engine rigging tube is restricting engine movement.
- Damaged steering cylinder body.
- Too small of a steering hoses being used.
- Steering wheel is too small.
- Tilt bellows interference.
- Cylinder installation procedure not followed correctly.
- Cylinder mounting plate is too tight.
- Consult with Engine Installation Manual for proper rigging tube installations.
- Replace steering cylinder(s) completely.
- Remove and re-plumb system using SeaStar outboard hoses.
- Wheel should be 15" & larger (MAX 26").
- Confirm no interference with rubber tilt bellows on steering wheel hub.
- Remove cylinder, re-install as per the steps noted.
- With cylinder not connected, the plate must move UP/DOWN freely. Replace if hard to move.

4. One helm in system is very bumpy and requires too many turns.

- Air in system.
- Dirt/debris in system.
- Dirt/debris in autopilot (if fitted).
- Bleed system.
- Replace helm pump, flush system (DO NOT attempt repair of helm).
- Replace autopilot pump.

TECHNICAL INFORMATION

Bolt Torque Specifications

Values are stated in: **in/lbs (N.m)**

Bolt Size	18-8SS	Brass
2-56	2.5 (.282)	2.0 (.226)
2-64	3.0 (.338)	2.5 (.282)
3-48	3.9 (.440)	3.2 (.361)
3-56	4.4 (.497)	3.6 (.407)
4-40	5.2 (.587)	4.3 (.486)
4-48	6.6 (.740)	5.4 (.610)
5-40	7.7 (.869)	6.3 (.712)
5-44	9.4 (1.06)	7.7 (.869)

These are the recommended maximum torque values for reusable dry bolts. Bolts should be torqued to this value +0% -20%. For lubricated bolts, multiply the dry bolt torque values by .75.

Bolt Size	18-8SS	Brass	Bolt Size	18-8SS	Brass
6-32	9.6 (1.08)	4.9 (.554)	5/16"-18	132.0 (14.91)	107.0 (12.10)
6-40	12.0 (1.35)	9.9 (1.12)	5/16"-24	142.0 (16.04)	116.0 (13.11)
8-32	20.0 (2.25)	16.0 (1.81)	3/8"-16	236.0 (26.66)	192.0 (21.71)
8-36	22.0 (2.48)	18.0 (2.03)	3/8"-24	259.0 (29.20)	212.0 (23.97)
10-24	23.0 (2.59)	19.0 (2.14)			
10-32	32.0 (3.61)	26.0 (2.94)			
1/4"-20	75.0 (8.47)	62.0 (7.01)			
1/4"-28	94.0 (10.6)	77.0 (8.70)			

Values are stated in: **ft/lbs (N.m)**

Bolt Size	18-8SS	Brass
7/16"-14	31.0 (42.00)	26.0 (35.25)
7/16"-20	33.0 (44.74)	27.0 (36.61)
1/2"-13	43.0 (58.30)	35.0 (47.45)
1/2"-20	45.0 (61.01)	37.0 (50.17)
9/16"-12	57.0 (77.28)	47.0 (63.72)
9/16"-18	63.0 (85.42)	51.0 (69.15)

Bolt Size	18-8SS	Brass
5/8"-11	93.0 (126.09)	76.0 (103.04)
5/8"-18	104.0 (141.00)	85.0 (115.24)
3/4"-10	128.0 (173.55)	104.0 (141.00)
3/4"-16	124.0 (168.12)	102.0 (138.29)
7/8"-9	194.0 (236.03)	159.0 (215.58)
7/8"-14	193.0 (261.67)	158.0 (214.22)

Bolt Size	18-8SS	Brass
1"-8	287.0 (389.12)	235.0 (318.62)
1"-14	259.0 (351.16)	212.0 (287.43)

Helm Pump

SeaStar 1.7
SeaStar 2.4
SeaStar Pro 2.0

DISPLACEMENT

1.7 cu. in. (27.8 cc)
2.4 cu. in. (39.3 cc)
2.0 cu. in. (33.0 cc)

RELIEF VALVE

1000 PSI (68 Bar)
1000 PSI (68 Bar)
1500 PSI (102 Bar)

PORTS

1/4" NPT
1/4" NPT
1/4" NPT

Helm Pump Shaft

SeaStar 1.7
SeaStar 2.4
SeaStar Pro 2.0

TAPER

3/4" Standard, 1" per ft.
3/4" Standard, 1" per ft.
3/4" Standard, 1" per ft.

THREAD

5/8" NF
5/8" NF
5/8" NF

KEY SIZE

3/16"
3/16"
3/16"

Cylinder

Front Mount (*Pivot, PRO
Pivot, Tournament Pivot*)

Front Mount (*Pivot, PRO
Pivot, Tournament Pivot*)

INSIDE DIAMETER

1.375" (34.93 mm)

VOLUME

8.34 cu. in. (136.6 cc)

STROKE

8" (203 mm)

TORQUE @ 1000 psi (70 Bar) H.O.

N/A

Fittings

SeaStar cylinders and all other fittings are 3/8" compression type fittings. Threads are 9/16" x 24 UNEF. A brochure on all SeaStar fittings is available from SeaStar Solutions.

SeaStar and SeaStar Pro Hose

Inside diameter – 5/16" (8 mm)

SEAL/REPLACEMENT PARTS

SEASTAR, FRONT MOUNT PIVOT CYLINDERS

Part # HC5345-3, HC5347-3, HC5348-3, HC5358-3, HC5375-3,
HC5445-3, HC6750, HC6751 and HC6345-3

Specifications

OUTBOARD USE ONLY

Volume: 8.3 cu.in.

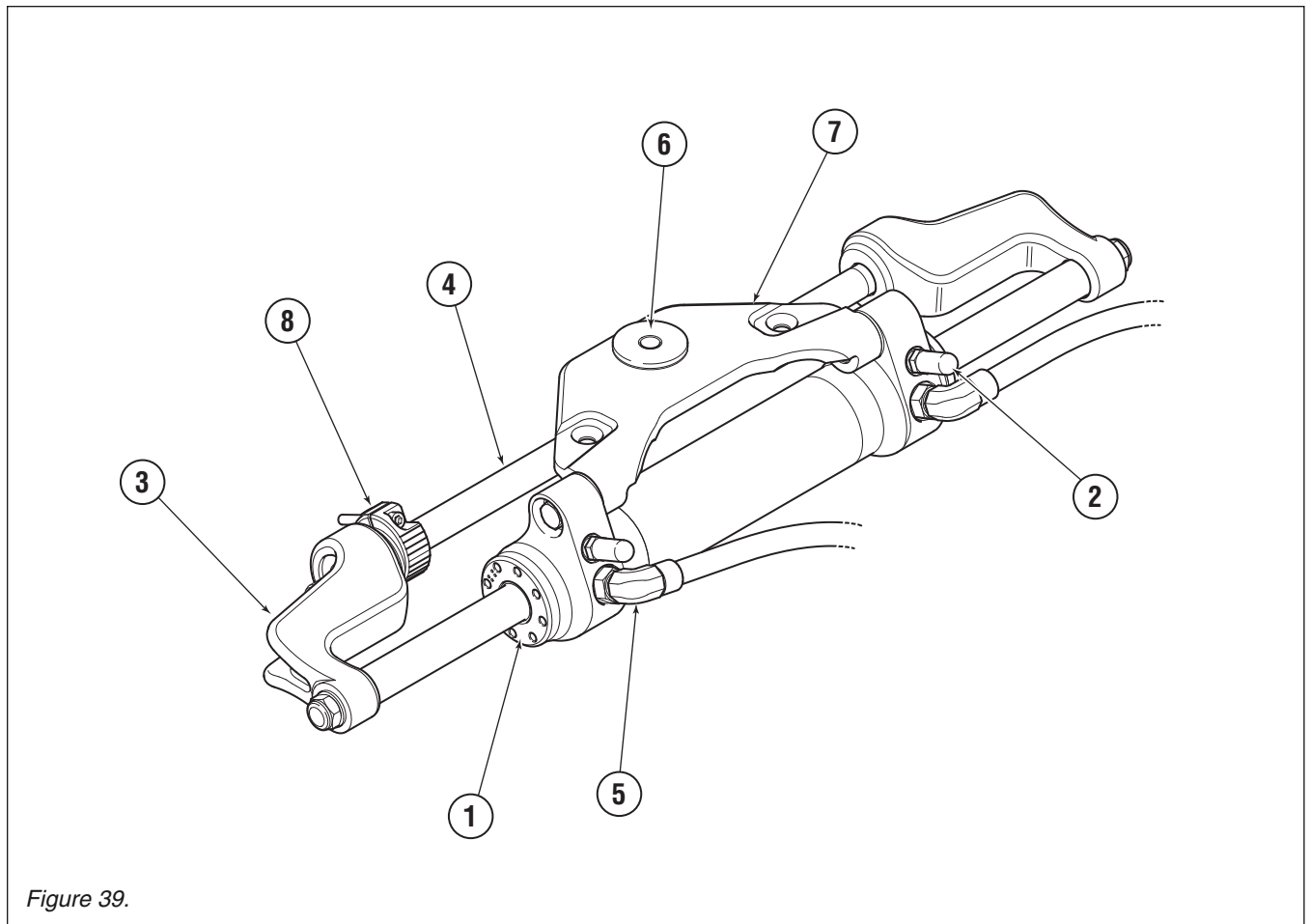

Figure 39.

ITEM	PART #	DESCRIPTION
1	HS5157	Seal Kit c/w wrench, does NOT include center/internal seal
2	HF5548	Bleeder Fittings, 2 per kit, covers NOT inc.
3	HP6018	Support Brackets, 2 per kit
4	HP6016	Support Rod
5	HF6004	Hose Elbow Fittings
6	HA5829	Tiller Bushing Kit, c/w high strength tiller bolt

ITEM	PART #	DESCRIPTION
7	N/A	Pivot Mount Plate <i>If damaged cylinder is to be replaced</i>
8	HP6033	Spacer/Adjusting Nut Kit
9	HF6005	Hose Tee Fitting <i>(Not shown)</i>
10	HA5477	Grounding Strap <i>(Not shown)</i>

SeaStar Power Purge JR.

Part# HA5445-2

SeaStar®/BayStar™ Power Purge Jr. is the quickest way to bleed a SeaStar®/ BayStar™ system in the field and assure a rock-solid steering feel every time!

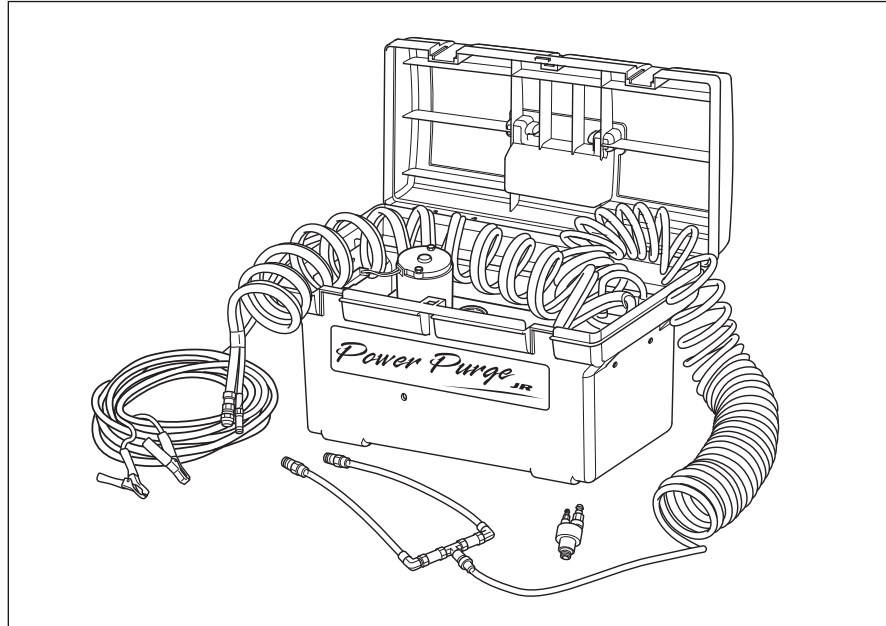

Figure 40.

Advantages:

- Steering feel is solid every time
- Complete Fill & Purge in 10 minutes or less
- Fast and efficient
- Easy to operate
- Screens contaminants from oil
- Quick connect fittings
- Convenient portable size
- Convenient electrical hook-up utilizing 12 volt boat battery
- Optional Dual Cylinder Purging Kit HA5461 available
- Optional 50' Hose Extension Kit HA5462, for longer runs

Statement of Limited Warranty

We warrant to the original retail purchaser that **Marine Canada Acquisition Inc. DBA SEASTAR SOLUTIONS** (herein forward referred to as **SeaStar Solutions**) products have been manufactured free from defects in materials and workmanship. This warranty is effective for two years from date of purchase, excepting that where **SeaStar Solutions** products are used commercially or in any rental or income producing activity, then this warranty is limited to one year from the date of purchase.

We will provide replacement product without charge, for any **SeaStar Solutions** product meeting this warranty, which is returned (freight prepaid) within the warranty period to the dealer from whom such product were purchased, or to us at the appropriate address. In such a case **SeaStar Solutions** products found to be defective and covered by this warranty, will be replaced at **SeaStar Solutions** option, and returned to the customer.

The above quoted statement is an extract from the complete **SeaStar Solutions** products warranty statement. A complete warranty policy is available in our **SeaStar Solutions** products catalogue.

Return Goods Procedure

Prior to returning product to **SeaStar Solutions** under warranty, please obtain a *Return Goods Authorization number* (claim number).

Be sure to label the goods with:

- a) the name and address of the sender, and
- b) the return goods authorization number (claim number)

Please address the returned goods as follows:

From U.S.A.

RGA # ?
SeaStar Solutions
c/o UPS-Supply Chain Solutions Inc.
Door A37
1201 C Street NW, Auburn, WA,
98001

From Canada

RGA # ?
SeaStar Solutions
3831 No. 6 Road
Richmond, B.C.
Canada V6V 1P6

Technical Support

Phone: 604-248-3858

email: seastar@seastarsolutions.com

Hours: Monday - Friday 05:00 – 15:30 PST

Web: www.seastarsolutions.com



**SEASTAR
SOLUTIONS®**

SEASTAR SOLUTIONS
3831 NO.6 ROAD
RICHMOND, B.C.
CANADA V6V 1P6

FAX 604-270-7172

www.seastarsolutions.com

ISO 10592



© 2014 MARINE CANADA ACQUISITION INC.
DBA SEASTAR SOLUTIONS

PRINTED IN CANADA

FORM NO. 929784 03/14 Rev. A