

MEMBER
ABYC
Setting Standards for Safer Boating®

INSTALLATION INSTRUCTIONS AND OWNERS MANUAL

Part # ISCHX82, Rev 0, 09/2016

www.seastarsolutions.com



CHX8200



CHX8700

*xtreme
ch2200
mt3
pro-trim
single s
twin s*

MECHANICAL ENGINE CONTROLS
CHX8200 and CHX8700 SERIES

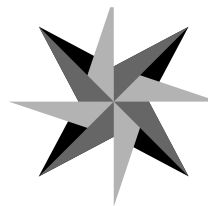

SEASTAR
SOLUTIONS®

*Before you do it your way,
please try it our way.*

MANUFACTURED BY
MARINE ACQUISITION INCORPORATED
DBA SEASTAR SOLUTIONS
U.S.A.

MECHANICAL ENGINE CONTROLS

CHX DUAL SERIES

NOTICE

Installer: these instructions contain important safety information and must be forwarded to the boat owner.

This SeaStar Solutions Control provides both shift and throttle operation for inboards, outboards, and inboard/outboards.

In addition to this control, the following components are required for a complete control system:

- *Four (4) control cables. Check section 2 of installation instructions for routing and length. SeaStar Solutions Xtreme™ cables are recommended.*

Adaptability of Control Cable: This control will connect to any current 3300/33C OEM-type cable. A cable nest kit (P/N 212151-004) which mates to the engine's shift and throttle cable, is included with this control. Unique cable nests, which are required for Mercury Gen II engines only, must be purchased separately. (See page 12)

CONTROL FEATURES	CHX8200	CHX8700
Single Lever Shift and Throttle Operation	Yes	Yes
Neutral Throttle Warm-Up	Yes	Yes
Neutral Throttle Interlock	Option	Option
Neutral Safety Switch (to prevent starting in gear)	Yes	Yes
Friction Adjust Screw (to prevent throttle "creep")	Yes	Yes
Trim Switch	Option	Option
Trim & Tilt Switch	Option	Option
Emergency Ignition Interrupt Switch & Lanyard	N/A	N/A

NOTICE

Cable installation and connections must be made in accordance with the motor manufacturer's instructions.

To insure best performance, free operation of all linkages and the remote control is essential. Follow the manufacturer's recommended procedures for adjustment and lubrication.

All specifications and features are subject to change without notice.

⚠ WARNING

Before starting installation read these instructions and engine makers instructions thoroughly. Failure to follow either of these instructions or incorrect assembly can result in loss of control and cause property damage, injury, or death.

⚠ WARNING

DO NOT substitute parts from other manufacturers, they may cause a safety hazard for which SeaStar Solutions cannot accept responsibility.

NOTICE

SeaStar Solutions highly recommends the installation and usage of an engine shut off switch as a important emergency safety feature for boats. This switch should be connected by a cord to the boat driver. Should the driver be thrown from the helm position, the engine will automatically shut off.

If this shut off switch is not a standard part of the control being used, it can be obtained from most marine dealers and distributors.

Control Features and Operation

(Option Numbers correspond to diagrams below)

1. NEUTRAL THROTTLE WARM-UP BUTTON.

This feature provides a throttle only option to warm-up the engine before driving the boat.

When the Control Hand Lever is in **Neutral**, push and hold the button at the base of the handle. While holding the button (1), move the lever forward to throttle up the engine.

When you return the handle to the Neutral position, the button will reset automatically.

Once the button resets, the hand lever will work both shift and throttle functions.

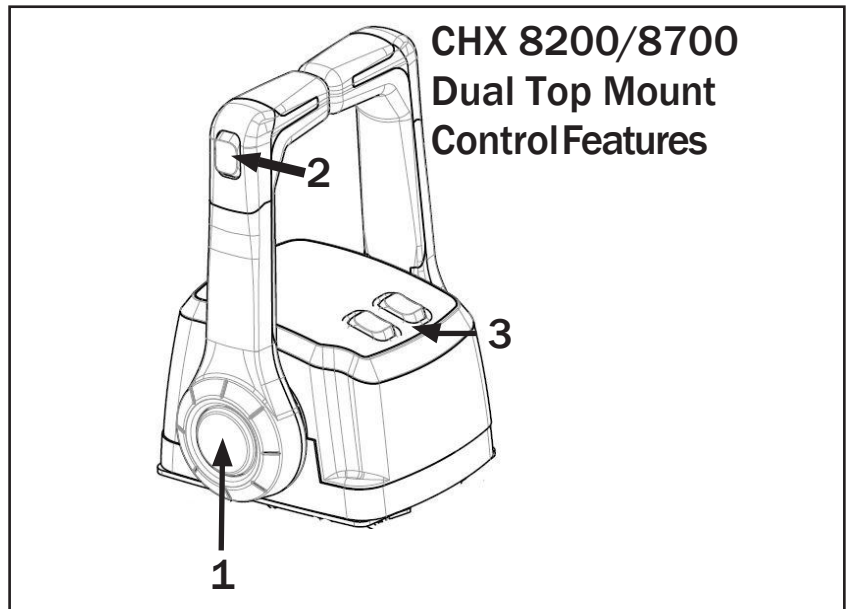

NOTICE

On models with Neutral Interlock, you must activate both the Neutral Interlock Lifter and the Neutral Warm-up Button together and move the handle forward.

2. MASTER ENGINE TRIM SWITCH.

Used to move both engines UP or DOWN to level the boat while underway. This switch controls trim and tilt on most outboards (option on top mount).

3. INDEPENDENT ENGINE TRIM SWITCHES.

Used to move the engine UP or DOWN to level the boat while underway. This switch controls trim and tilt on most outboards (option on top mount).

4. TRAILER (TILT) SWITCHES (NOT SHOWN).

Used to raise the engine for trailering the boat. This switch normally is used on I/O applications (option on top mount).

5. NEUTRAL INTERLOCK LIFTER (NOT SHOWN).

To prevent bumping the control out of neutral, the lifter must be activated and held to shift into forward or reverse (option on top mount).

Installation

SECTION 1: LOCATION OF CONTROL.

STEP 1. Allow adequate clearance for hand lever swing (forward and reverse positions).

STEP 2. Allow adequate clearance under the console or in the gunwale for the cables AND **allow a minimum of 36" from the cable nest connection with no restraint.** When supporting the cables beyond 36", do not tie or clamp tightly.

STEP 3. After a suitable location for the control is determined, use the separate mounting template.

STEP 4. Closely follow the instructions provided on the template. Cut and drill the mounting holes required.

On all models, the cover will have to be removed to expose the mounting holes.

TOOLS FOR INSTALLATION:

Phillips head screwdrivers	Standard slot screwdriver
Saber saw	4 1/4" Hole saw (optional)
Power drill	7/32" and 17/64" drill bits
3/8" box end wrench	Multimeter (optional)
5/8" or 16mm deep well socket	Ratchet wrench

SECTION 2: MEASURING THE CABLES.

Measure the cable routing path from the control head connection to the engine connection.

OUTBOARDS:

Measure from the control connection—along an unobstructed cable routing—to the center of the outboard engine.

Add four (4) feet to the measurement to allow for a loop which provides unrestricted engine movement. Round **UP** to the next whole foot and order the required cable part number.

(Last two digits of the SeaStar Solutions cable number equal the length of the cable in feet.)

INBOARDS AND STERNDRIVES:

Measure from the control connection—along an unobstructed cable routing—to the shift or throttle connection. Round this dimension **UP** to the next whole foot and order the required cable part number.

(Last two digits of the SeaStar Solutions cable number equal the length of the cable in feet.)

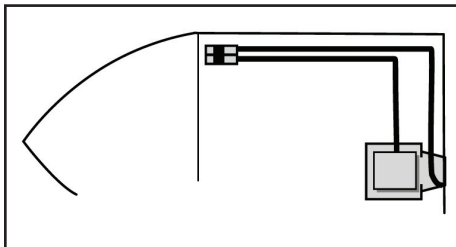
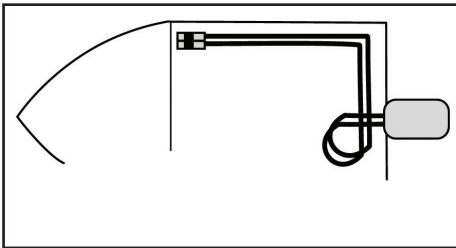

Installation of Cables

A. BEND RADIUS. When routing the control cables, select a path with the minimum number of bends, making the bends as large as possible. Sharp or frequent bends will result in difficult throttle or shift control, loss of motion, and premature cable wear. **DO NOT MAKE BENDS OF LESS THAN THE RECOMMENDED MINIMUM BEND RADIUS AS NOTED BELOW.**

Cable Type	<i>Minimum Bend Radius</i>
Standard	8"
Xtreme	4"

For best performance, SeaStar Solutions recommends using Xtreme cables with this control.

B. SUPPORTING THE CABLE. Do not tie or clamp the cable within 36 inches of the control. When supporting the cable beyond 36 inches of the control, cables should be loosely clamped or tied for support at regular intervals.

CAUTION

Cables must not be bundled together with electrical wiring.

Cables must not rest on sharp edges which can cause chafing.

C. CABLE ROUTING. Cables shall not be installed in areas of excess heat such as on, or close to, exhaust manifolds where temperatures may exceed 212 °F (100 °C).

SECTION 3: SHIFT & THROTTLE CABLE CONNECTION-CONTROL END.

- **PUSH/PULL** refer to the direction of cable motion to shift into “forward” or to “open” the throttle.
- Refer to the appropriate manufacturer’s manual for shift and throttle direction and adjustments.
- **Numbered holes on mechanism chassis correspond to holes in shift and throttle levers** (for example: connect cable mount to hole 4 on chassis and cable end fitting to hole 4 on lever).
- Cables and wiring should be pre-installed on control before final mounting is made.

Cable Connection Guide

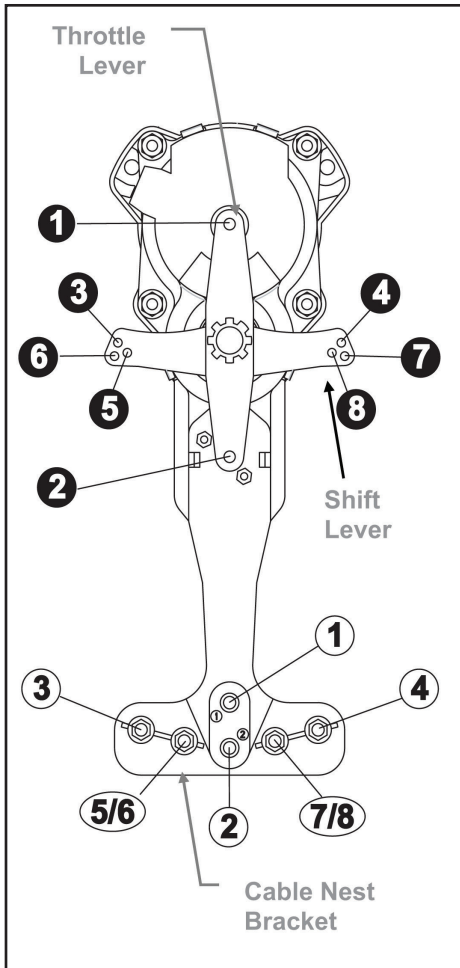

Cable Mounting Diagram

NOTE:

I/O = Inboard/Outboard or Sterndrive.
O/B = Outboard.

PUSH to OPEN THROTTLE				
	PORT INSTALLATION		STARBOARD INSTALLATION	
MANUFACTURER	CABLE NEST KIT	THROTTLE LEVER	CABLE NEST KIT	THROTTLE LEVER
Mercury 18 & 25 HP	#1	#1	#1	#1
Johnson/Evinrude	#1	#1	#1	#1
BRP/OMC I/O	#1	#1	#1	#1
Yamaha 90HP & up	#1	#1	#1	#1
US Marine	#1	#1	#1	#1
Suzuki	#1	#1	#1	#1

PULL to OPEN THROTTLE				
	PORT INSTALLATION		STARBOARD INSTALLATION	
MANUFACTURER	CABLE NEST KIT	THROTTLE LEVER	CABLE NEST KIT	THROTTLE LEVER
MerCruiser Mercury I/O & OB	#2	#2	#2	#2
Volvo	#2	#2	#2	#2
Yamaha 70HP & Under	#2	#2	#2	#2
Honda	#2	#2	#2	#2
Nissan/Tohatsu	#2	#2	#2	#2

PUSH for FORWARD SHIFT				
	PORT INSTALLATION		STARBOARD INSTALLATION	
MANUFACTURER	CABLE NEST KIT	SHIFT LEVER	CABLE NEST KIT	SHIFT LEVER
Volvo I/O & Inboards	#3	#3	#4	#4
3300 Cables	#3	#3	#4	#4
Mercury 18 & 25 HP	#5/6	#6	#7/8	#7
Inboards	#3	#3	#4	#4

PULL for FORWARD SHIFT				
	PORT INSTALLATION		STARBOARD INSTALLATION	
MANUFACTURER	CABLE NEST KIT	SHIFT LEVER	CABLE NEST KIT	SHIFT LEVER
3300 Cables	#4	#4	#3	#3
MerCruiser Mercury I/O & OB	#7/8	#7	#5/6	#6
BRP/OMC I/O Evinrude/Johnson	#7/8	#8	#5/6	#5
Honda/Nissan/Suzuki	#4	#4	#3	#3
Tohatsu/US Marine	#4	#4	#3	#3
Yamaha	#4	#4	#3	#3
Inboards	#4	#4	#3	#3

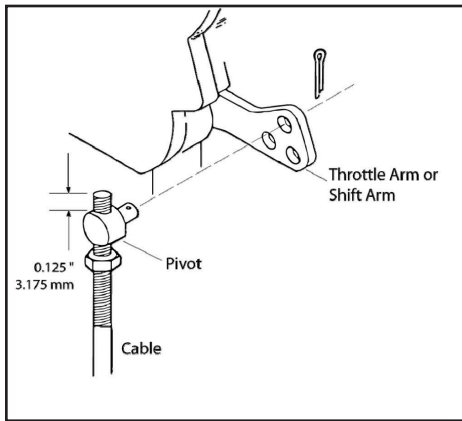

Shift Arm Cable Terminal Connection for 3300/33C Cable.

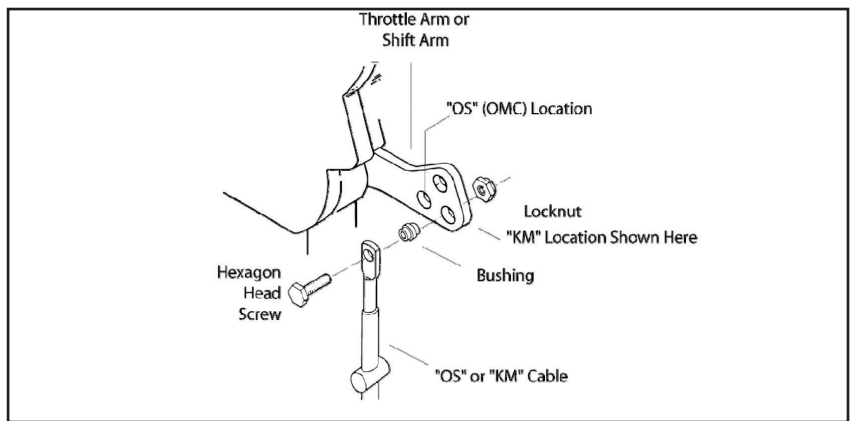

Shift Arm Cable Terminal Connection for "OS" is BRP/OMC/Johnson and Evinrude. "KM" is Mercury, MerCruiser.

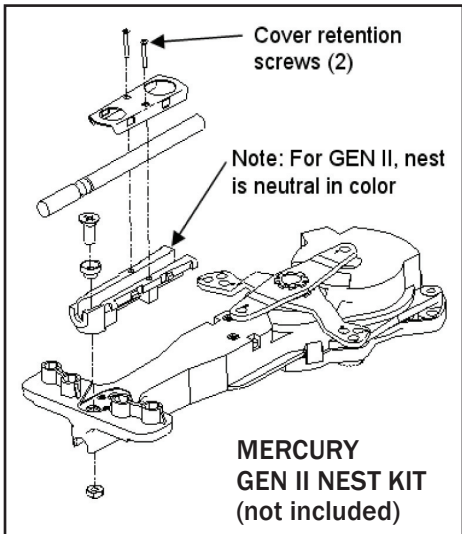

Cable End Options

- 3300/33C (Universal) (note black nest color)
 - BRP/OMC/Johnson/Evinrude (note black nest color)
 - Mercury, MerCruiser (note black nest color)
 - Mercury Gen II Cables (note neutral nest color)
- Each cable type connects differently.

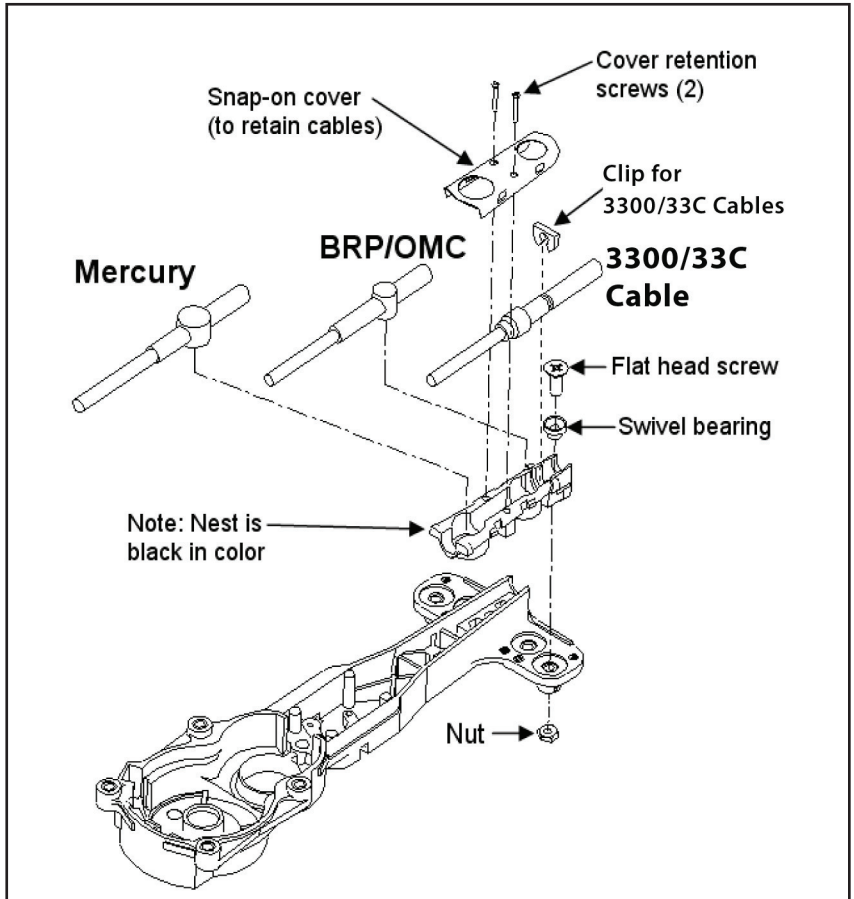

SECTION 4: SHIFT & THROTTLE CABLE CONNECTION-ENGINE END.

CAUTION

The throttle cable must be disconnected from the motor before making motor idle adjustments. Adjustment of the motor idle while the throttle cable is connected to the motor may cause jamming action against the idle stop. As a result, the control may not function properly and damage to the control, the cable and/or the motor may occur.

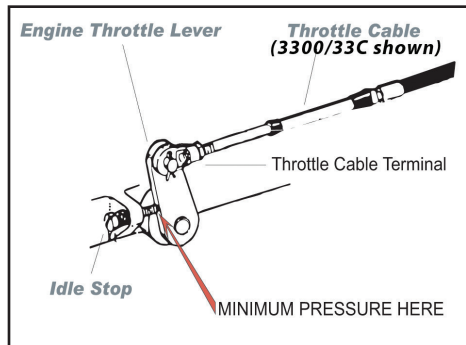

Please Note: This figure does not represent any particular engine.

STEP 1. Make sure the Control is in *NEUTRAL DETENT*.

STEP 2. The Engine Throttle Lever should rest lightly against the “Idle Stop” on the carburetor.

STEP 3. Connect the Throttle Cable to the Engine Throttle Lever.

STEP 4. Before connecting the shift lever to transmission lever, put both the control lever and the transmission lever into forward gear position. Adjust the cable end to the position where it easily slides onto transmission lever.

STEP 5. If using 3300/33C cables, tighten all jamb nuts against adaptors.

NOTICE

Throttle Cable must be free of load (NO LOAD) when throttle lever is in the idle position to prevent hard shifting.

SECTION 5: ELECTRICAL CONNECTIONS.

NEUTRAL SAFETY SWITCH.

This control is provided with a Neutral Safety Switch. This switch is used to prevent the engine from starting in gear.

NOTICE

Use a battery-powered test light or test meter to check continuity.

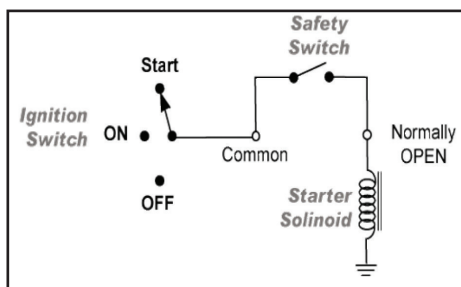

STEP 1. With the Control in NEUTRAL, connect one wire of the tester to the common terminal, and one wire to the “NO” (Normally Open) Terminal. The test light MUST light.

STEP 2. Connect the neutral safety switch between the ignition switch (start lead) and the starter solenoid.

CAUTION

Use a multimeter or continuity tester to make sure that there is electrical continuity only when the control is in neutral position. When the control is in forward or reverse gear there must not be electrical continuity. The multimeter or tester should show an open circuit.

TRIM AND TILT.

Refer to the following wiring diagrams for the correct “Trim” and “Tilt” switch connections and wire accordingly.

Abbreviations:

DN = Down

UP = Up

Color Key:

B = Blue

G = Green

V = Violet

R = Red

W = White

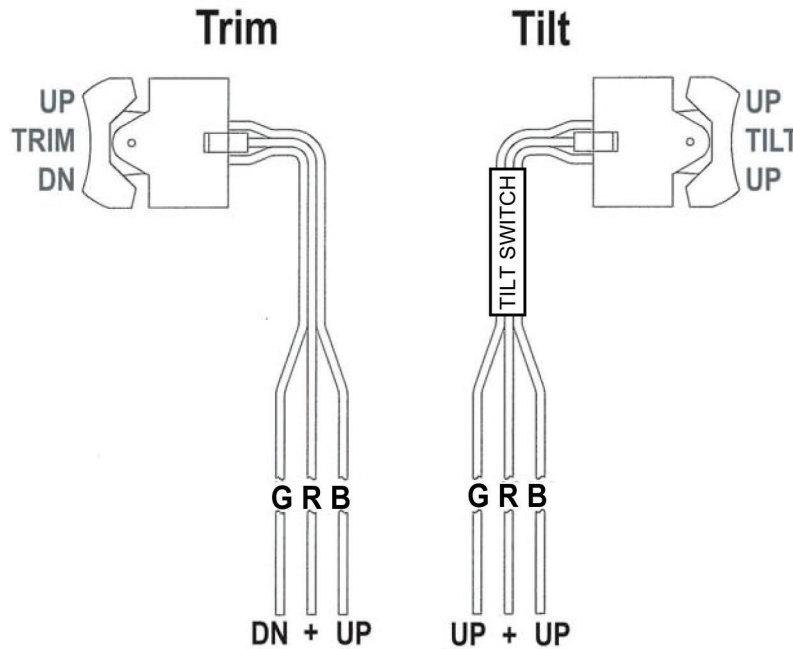

Note for Tilt:

1. Connect Blue and Green together, then connect to engine tilt signal wire.

2. Connect Red to engine power wire.

3. Not all engines are wired the same, especially older engines. Check with the engine manufacturer for wiring specifications.

4. Use either the upper or lower Tilt switch to bring Tilt UP. To bring Tilt DOWN, use Trim DOWN switch.

All wiring, connections and terminations should be done in accordance with ABYC Spec E 11-03.

INSTALLATION (TOP MOUNT)

STEP 1. Cut opening in console per included Mounting Template.

STEP 2. Align the mechanism and gasket with the four screwholes.

STEP 3. Install the four bolts, lockwashers and nuts through the bezel base.

STEP 4. Install the bezel cover.

Note: To remove the bezel cover, apply forward force on the back port corner of the cover while rotating the back counter clockwise until the back snap disengages. Then apply rearward force to the front of the bezel while gently lifting the assembly and rotating the front clockwise until the front snap disengages.

DO NOT APPLY EXCESSIVE FORCE as this may result in breakage of the snap features.

General Control Dimensions

CHX8200: DUAL TOP-MOUNT CONTROL GENERAL DIMENSIONS.

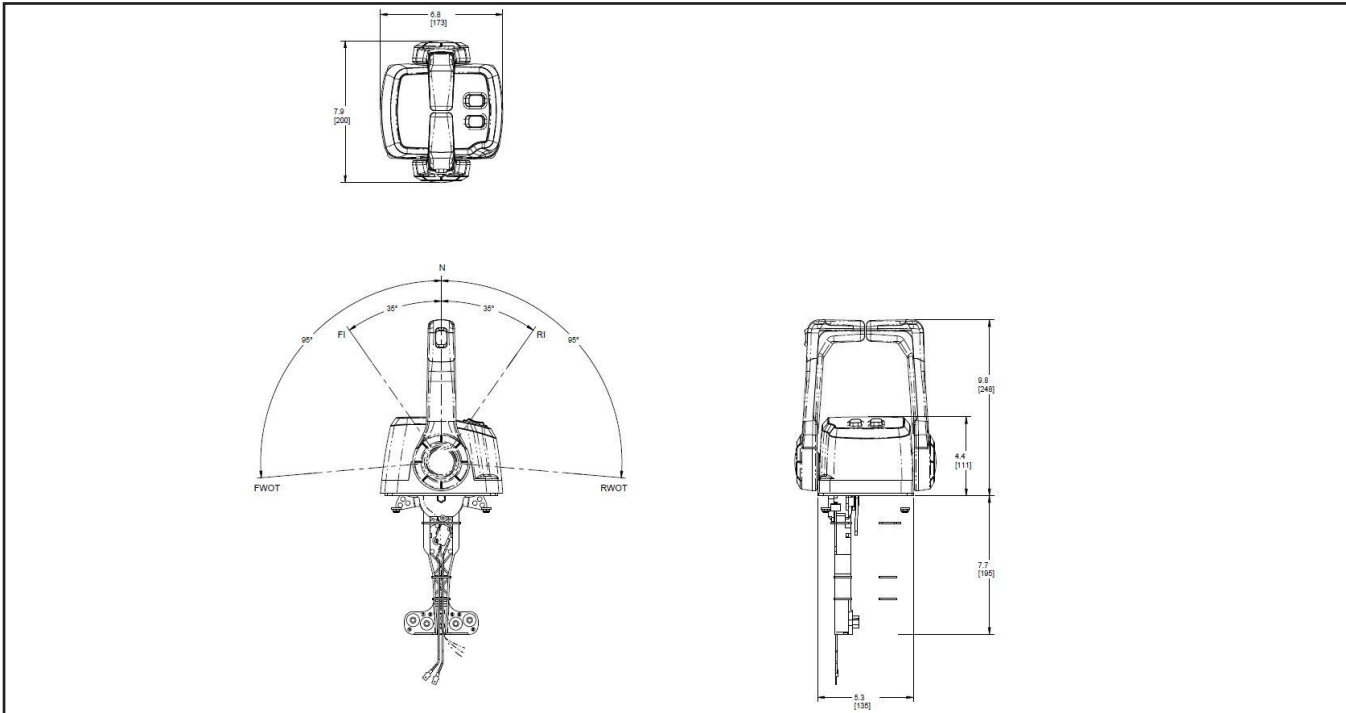

Exploded View CHX8200

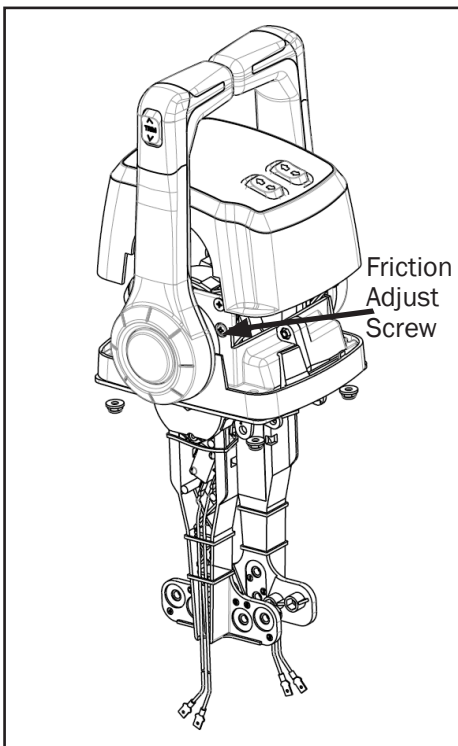

FRICION ADJUST SCREW.

Adjustment of this screw enables the friction in the throttle operating mechanism to be increased and prevent unwanted handle movement. To adjust, place the lever in the forward or reverse throttle position (just beyond the shift position). Remove the cover and adjust the friction adjust screw: turning the screw clockwise increases the friction. Do not over-tighten.

CHX Mounting Template

Single & Twin Top Mount Controls

Panel Cut Out (Full Size)

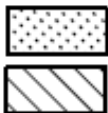
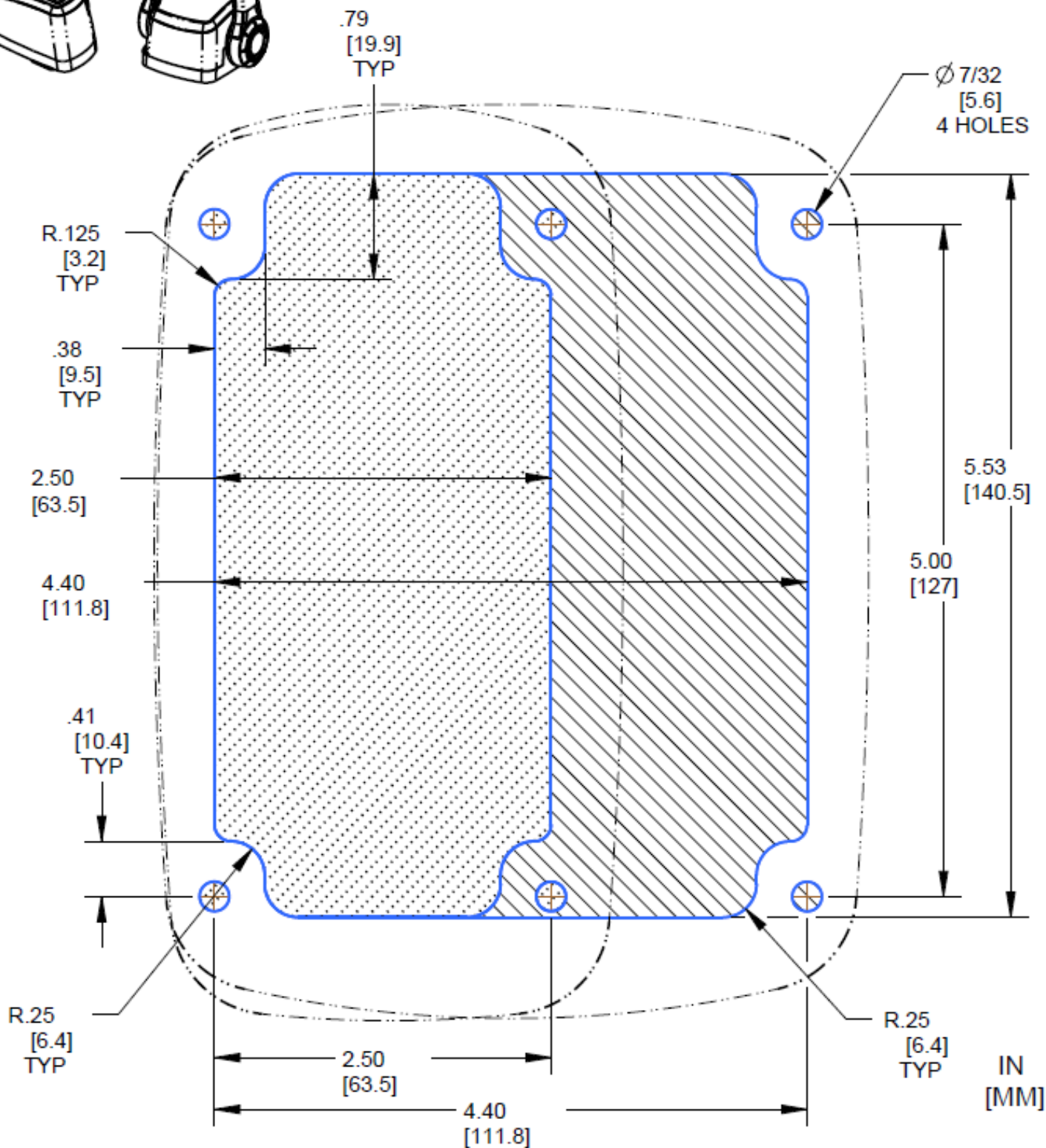
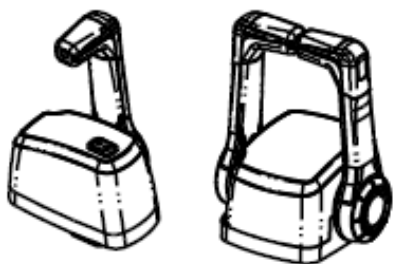

REMOVE ENTIRE HATCHED AREA WHEN MOUNTING BOTH SINGLE & TWIN CONTROLS ON TOP OF PANEL.

REMOVE THIS AREA WHEN MOUNTING TWIN CONTROL ON TOP OF PANEL.

NOTICE

This template may not be to scale. Its presence is for information purposes. A separate work template—MT-CHX81 has been included with this control.

Maintenance Notes

1. After a few hours of operation and at frequent intervals thereafter, check all fasteners and the complete control system for security and integrity.

DANGER

Loosening or loss of one or more fasteners may cause failure of the control system and could cause property damage, injury, or death.

2. Keep all moving parts free from build-up of salt and other foreign material. This will affect their operation and create control problems.

3. Periodically inspect for corrosion. Any parts affected by corrosion must be replaced. Any replacement hardware must be as originally supplied (i.e. similar material and locking features).

4. Periodically inspect control cables for cracks and other damage. If any is found the cable must be replaced.

5. If cable is stiff in operation, it is unsafe to use and must be replaced immediately.

DANGER

DO NOT cover cracks with tape or other sealants. This will create a hazard in which the cable can fail suddenly without warning, resulting in property damage, injury, or death.

6. Periodically treat exposed metal components with a marine grade wax.

NOTICE

Boat builder and boat dealer, please supply these Installation Instructions and Owner's Manual with the delivery of boat. Boat owner keep these instructions with your boat for future reference. Boat owner consult with your boat builder, boat dealer, or SeaStar Solutions if you have any questions regarding these instructions.

Service Parts Kits

All service parts can be purchased from your local SeaStar Solutions Distributor.

KIT NUMBER	KIT NAME AND DESCRIPTION	MODEL USED ON
212151-003	Cable Nest and Connection Kit with Mercury Gen II Nest	All
051801-023	Neutral Safety Switch	All
CHX8200 REPLACEMENT PARTS		
	Neutral Throttle Warm-up Kit (Top Mount)	
	Tilt Switch Kit	

THIS PAGE INTENTIONALLY
LEFT BLANK

THIS PAGE INTENTIONALLY
LEFT BLANK



**SEASTAR
SOLUTIONS®**

640 North Lewis Road
Limerick, PA 19468 USA
610-495-7011
www.seastarsolutions.com



© 2016 MARINE ACQUISITION (US) INC.

PART # ISCHX82 08-2016 Rev. 0