

CE



B103



B104

SINGLE LEVER TOP MOUNT CONTROLS

Single lever / dual action control to operate both throttle and shift.
Suitable for any type of boats with outboard, inboard or I/O power plants.

FEATURES

- Enables easy and safe shifting by preventing accidental gear engagement unless engine is idling
- Made of marine aluminum, chrome plated or powder coat finish
- Pull-out handle disengages shift for warm-up
- Neutral safety switch X12 - 34543 Q prevents in-gear starting
- Power trim switch conveniently located in the handle grip enables for easy tilting of the engine
- For use with:
 - All Ultraflex control cables except C22 and C4
 - Mercury® \ current OMC® \ Yamaha® \ Suzuki® Honda® \ Volvo® style cables
 - 33C style cables
- Ultraflex C5, C16 and Mercury® cables require K35 kit - 34730 U
- Exceeds EN 11547 standard when X12 safety switch is installed

MODELS

- | | |
|----------------------|---|
| B65 - 34731 V | Single lever control for one engine, chrome plated |
| B76 - 35312 E | Single lever control for one engine, chrome plated, with trim. |
| B66 - 34732 W | Twin lever control for two engines, chrome plated |
| B78 - 35314 G | Twin lever control for two engines, chrome plated, with trim. |
| B73 - 35007 T | Single lever control for one engine, black dome, chrome plated lever. |
| B77 - 35313 F | Single lever control for one engine, black dome, chrome plated lever, with trim |
| B74 - 35008 B | Twin lever control for two engines, black dome, chrome plated lever. |
| B79 - 35315 H | Twin lever control for two engines, black dome, chrome plated lever, with trim. |

B65
B76 with trim



B66
B78 with trim

B73
B77 with trim



B74
B79 with trim

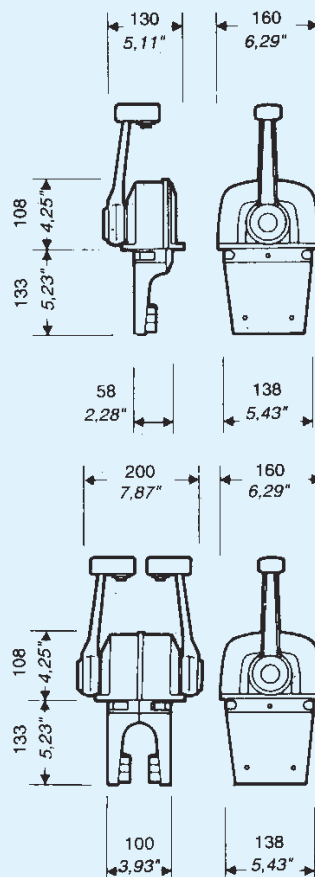

Handle with trim





SINGLE LEVER SIDE MOUNT CONTROLS

Single lever / dual action control to operate both throttle and shift.
Suitable for any type of boats with outboard, inboard or I/O power plants.

FEATURES

- Enables easy and safe shifting by preventing accidental gear engagement unless engine is idling
- Can be installed horizontally or vertically, on the starboard or port side of the boat
- The lever assembly is made of painted marine aluminum
- Provided with a brake tension release system adjustable from outside
- Pull-out handle disengages shift for warm-up
- Neutral safety switch **X12** - 34543 Q (for B183, B184, B85) or **X50** - 38817 S (for B184Merc) prevents in-gear starting
- All models are provided with positive lock-in neutral to prevent accidental gear engagement
- B184 model is provided with a power trim switch conveniently located in the handle grip that enables for easy tilting of the engine
- For use with:
 - All Ultraflex control cables except C4
 - Mercury® \ current OMC® \ Yamaha® \ Suzuki® \ Honda® \ Volvo® style cables
 - 33C style cables
- Ultraflex C5 and C16 and Mercury® cables require **K35** - 34730 U connection kit
- Ultraflex C22 and C23 cables require **KB1** - 39964 L connection kit
- Exceeds EN 11547 standards when X12 or X50 safety switch is installed

MODELS

- B183** - 38945 B
Provided with a positive lock-in neutral
- B184** - 38946 D
Provided with a positive lock-in neutral and trim switch
- B85** - 35682 I
Standard model, smooth design for use on sailboats. Provided with a positive lock-in neutral.
- B184Merc** - 39773 D
For MERCURY® or MERCURUISER® engines. It includes **X50** - 38817 S neutral safety switch for trim and tilt functions and **K35** - 34730 U connection kit for Mercury® cables.



B183



B184



B85

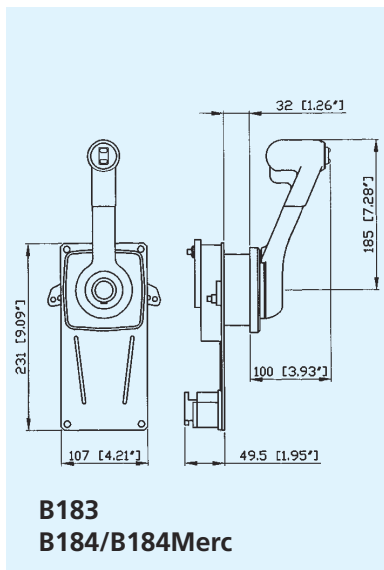

B183
B184/B184Merc

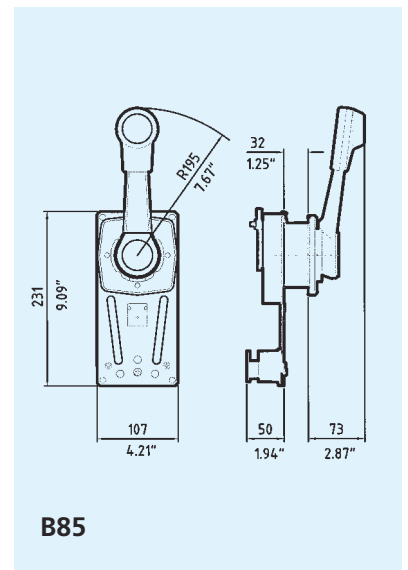

B85

SINGLE LEVER SIDE MOUNT CONTROLS

Single lever / dual action control to operate both throttle and shift.
Suitable for any type of boats with outboard, inboard or I/O power plants.

FEATURES

- Enables easy and safe shifting by preventing accidental gear engagement unless engine is idling
- Can be installed horizontally or vertically, on the starboard or port side of the boat
- Made of painted marine aluminum
- Pull-out handle disengages shift for warm-up
- Neutral safety switch X12 - 34543 Q prevents in-gear starting
- Provided with a positive lock-in neutral to prevent accidental gear engagement
- For use with:
 - All Ultraflex control cables except C22 and C4
 - Mercury® \ current OMC® \ Yamaha® \ Suzuki®
 - Honda® \ Volvo® style cables
 - 33C style cables
- Ultraflex C5, C16 and Mercury® cables require **K35** - 34730 U connection kit.
- To connect C14 cable and current OMC® cable to engine, use **K51** - 32526 N connection kit.
- Exceeds EN 11547 standards when X12 safety switch is installed

MODELS

B89 - 36151 G
White finish with positive lock-in neutral.

B90 - 36152 H
Black finish with positive lock-in neutral.

B89



B90

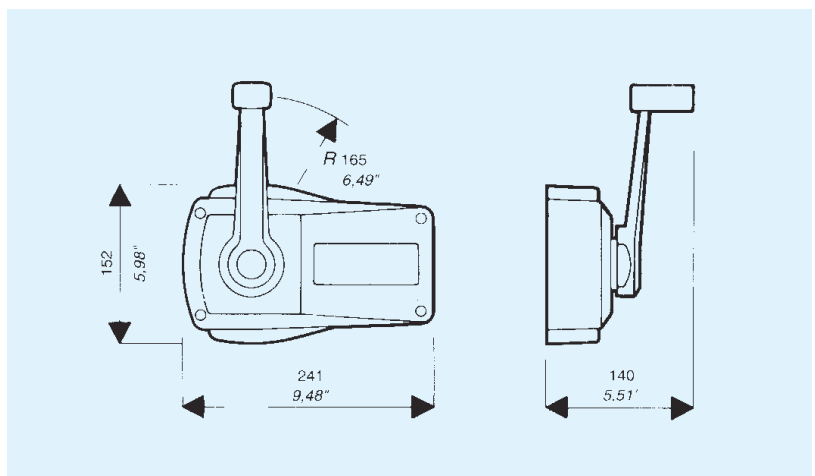

23



TWO LEVER TOP MOUNT CONTROLS

Two lever / single action control: each lever operates separately either the throttle or shift. Suitable for use with outboard, inboard or I/O power plants.

FEATURES

- All the four versions are provided with the shift lever detents and with a brake tension release system adjustable from the outside of the throttle lever
- Neutral safety switch X12 - 34543 Q prevents in-gear starting
- Suitable for exposed positions such as flying bridge
- For use with Ultraflex C2, C8, CZero and all 33C style engine control cables
- Ultraflex C22 and all 43C style cables requires K32 - 34662 Z connection kit
- Exceeds EN 11547 standards when X12 safety switch is installed

MODELS

- B99 - 36854 N Throttle and shift. Black painted with chrome levers
- B99T - 36938 S Throttle only. Black painted with chrome levers
- B99S - 36896 B Shift only. Black painted with chrome levers
- B100 - 36855 O Throttle and shift. Sport black levers.
- B100T - 36940 K Throttle only. Sport black levers.
- B100S - 36897 C Shift only. Sport black levers.
- B101 - 36856 P Throttle and shift. White painted.
- B101T - 36942 M Throttle only. White painted.
- B101S - 36898 F Shift only. White painted.
- B102 - 36899 G Throttle and shift. Black painted.
- B102T - 36992 A Throttle only. Black painted.
- B102S - 36900 C Shift only. Black painted.
- X54 - 39340 V Silver knob for B99-B100-B101-B102.

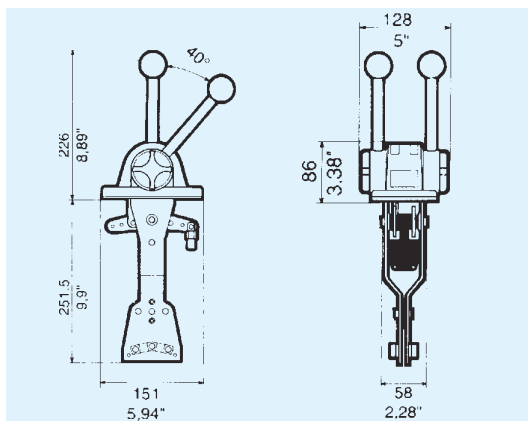

TWO LEVER TOP MOUNT CONTROLS

Two lever / single action control: each lever operates separately either the throttle or shift. Suitable for use with outboard, inboard or I/O power plants.

FEATURES

- Flush mount suitable for exposed positions such as flying bridge
- Made of marine aluminum with chrome plated lever
- Throttle lever is provided with adjustable brake tension release system and shift lever with forward, reverse and neutral detents. Both the brake tension release and detents can be installed and adjusted from the outside.
- Neutral safety switch **X12** - 34543 Q prevents in-gear starting
- Available with straight or bent levers
- B58 and B59 models are provided with an interlock kit to prevent accidental gear engagement
- For use with Ultraflex C2, C8, CZero and all 33C style engine control cables.
- Ultraflex C22 and all 43C style cables requires **K22** - 34713 Q connection kit.
- Exceeds EN 11547 standards when X12 safety switch is installed
- Burl wood cover **optional**:
X51 - 38985 P

MODELS

BENT LEVERS:

- B46** - 34461 P Throttle and shift
B46T - 34462 Q Throttle only
B46S - 34463 R Shift only
B58R - 34570 W Throttle and shift. With interlock. Right hand installation
B58L - 34716 T Throttle and shift. With interlock. Left hand installation

STRAIGHT LEVERS:

- B50** - 34464 S Throttle and shift
B50T - 34465 T Throttle only
B50S - 34466 U Shift only
B59R - 34571 X Throttle and shift. With interlock. Right hand installation
B59L - 34717 U Throttle and shift. With interlock. Left hand installation

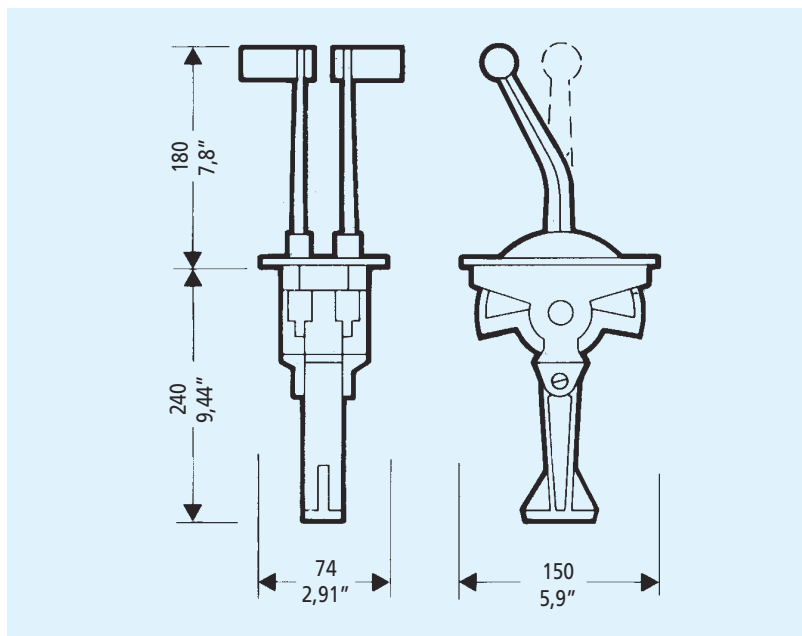

25



TWO LEVER TOP MOUNT CONTROLS

Two lever / single action control: each lever operates separately either the throttle or shift. Suitable for use with outboard, inboard or I/O power plants.

FEATURES

- Flush mount suitable for exposed positions such as flying bridge
- Levers structure made of die cast zinc provided with a soft thermoplastic ergonomical handgrip
- Adjustable brake to avoid throttle creep and positive detent for shift
- Adjustable ratchet for precise throttle operation obtained applying to the gas lever the optional kit **K52** - 37382 B
- Neutral safety switch **X12** - 34543 Q prevents in-gear starting
- Raked throttle handle and straight gear handle for a better manoeuvring
- B204 and B208 models are provided with an interlock kit to prevent accidental gear engagement
- For use with Ultraflex C2, C8, CZero and all 33C style engine control cables.
- Ultraflex C22 and all 43C style cables requires **K22** - 34713 Q connection kit.
- Exceeds EN 11547 standards when X12 safety switch is installed
- Burl wood cover **optional**:
X51 - 38985 P

MODELS

Black painted control with black soft hand grip:

- B203T** - 37380 Z Throttle only
- B203S** - 37381 A Shift only
- B203R** - 37378 A Throttle and shift.
Right hand installation
- B203L** - 37379 B Throttle and shift.
Left hand installation
- B204R** - 37383 C Throttle and shift. With interlock.
Right hand installation
- B204L** - 37384 D Throttle and shift. With interlock.
Left hand installation

White painted control with grey soft hand grip:

- B207T** - 37652 A Throttle only
- B207S** - 37653 B Shift only
- B207R** - 37650 Y Throttle and shift.
Right hand installation
- B207L** - 37651 Z Throttle and shift.
Left hand installation
- B208R** - 37654 C Throttle and shift. With interlock.
Right hand installation
- B208L** - 37655 D Throttle and shift. With interlock.
Left hand installation



**B207
B208 with interlock**



**BURL WOOD
COVER - X51**

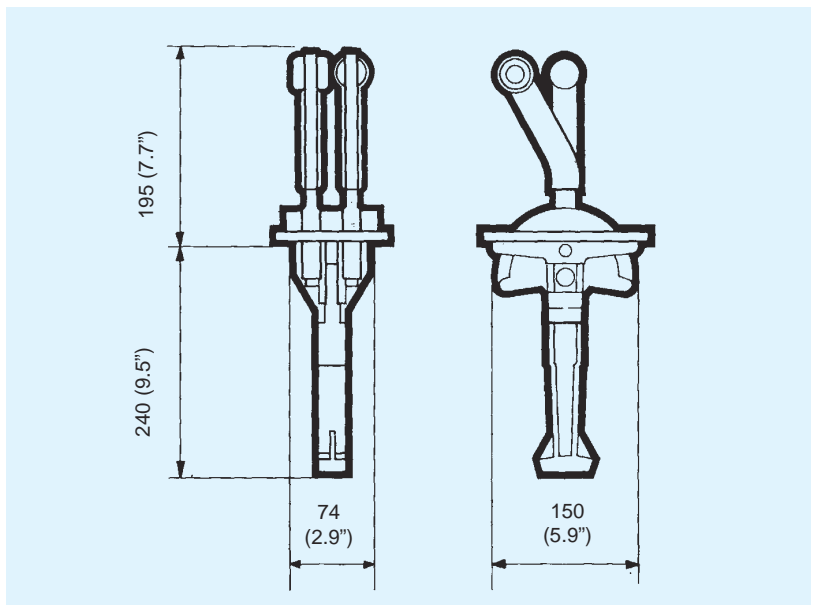

TWO LEVER TOP MOUNT CONTROLS

Two lever / single action control: each lever operates separately either the throttle or shift. Suitable for use with outboard, inboard or I/O power plants.

FEATURES

- Flush mount suitable for exposed positions such as flying bridge
- Levers structure made of die cast zinc burl wood or silver painted finish
- Adjustable brake to avoid throttle creep and positive detent for shift
- Adjustable ratchet for precise throttle operation obtained applying to the gas lever the optional kit **K52** - 37382 B
- Neutral safety switch **X12** - 34543 Q prevents in-gear starting
- Raked throttle handle and straight gear handle for a better manoeuvring
- B218 and B220 models are provided with an interlock kit to prevent accidental gear engagement
- For use with Ultraflex C2, C8, CZero and all 33C style engine control cables.
- Ultraflex C22 and all 43C style cables requires **K22** - 34713 Q connection kit.
- Exceeds EN 11547 standards when X12 safety switch is installed

MODELS

Burl wood cover and handles:

- B217T** - 38965H Throttle only
B217S - 38966K Throttle only
B217R - 38967M Throttle and shift.
 Right hand installation
B217L - 38968P Throttle and shift.
 Left hand installation
B218R - 38969S Throttle and shift. With interlock.
 Right hand installation
B218L - 38970A Throttle and shift. With interlock.
 Left hand installation

Silver painted cover and handles:

- B219T** - 38971C Throttle only
B219S - 38972E Shift only
B219R - 38973G Throttle and shift.
 Right hand installation
B219L - 38974J Throttle and shift.
 Left hand installation
B220R - 38975L Throttle and shift. With interlock.
 Right hand installation
B220L - 38976N Throttle and shift. With interlock.
 Left hand installation

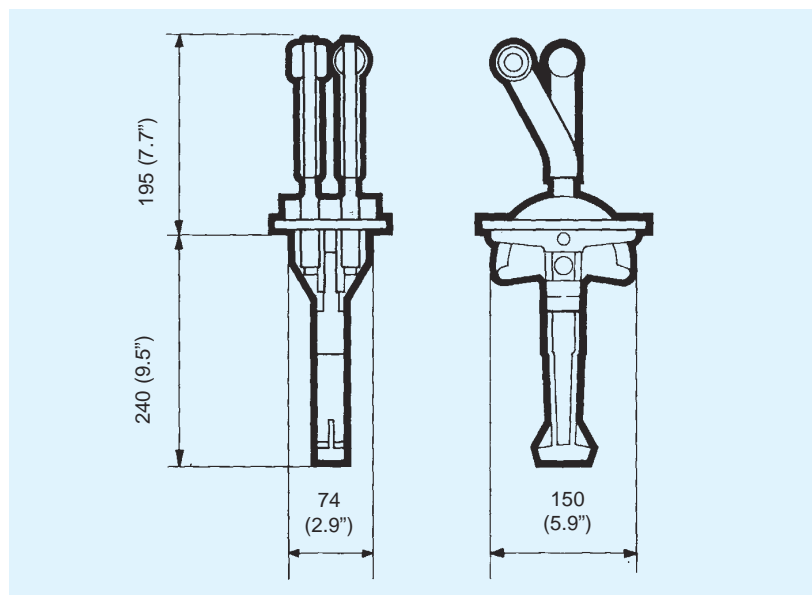



SINGLE ACTION CONTROLS

28

B47 AND B49 TWO LEVER CONTROLS

Suitable for all outboard engines.

FEATURES

- Made of nylon fiberglass with anodized aluminum levers
- Left or right side mount installation
- For use with Ultraflex engine control cables:
 - C14 with **K23** - 32773 D connection kit
 - C4 with **K24** - 32774 E connection Kit
 - C2, C8, CZero and all 33C style cables with **K25** - 32775 F connection kit
 - C5 without connection kit
 - Mercury® no connection kit needed
 - OMC® pre 1979 w/**K24**
 - OMC® post 1979 w/**K23**
 - Yamaha® w/**K25**
 - Honda® w/**K25**
 - Suzuki® w/**K25**

MODELS

- B47** - 32770 A - Light grey finish
- B49** - 33283 S - Black finish



B47

B49

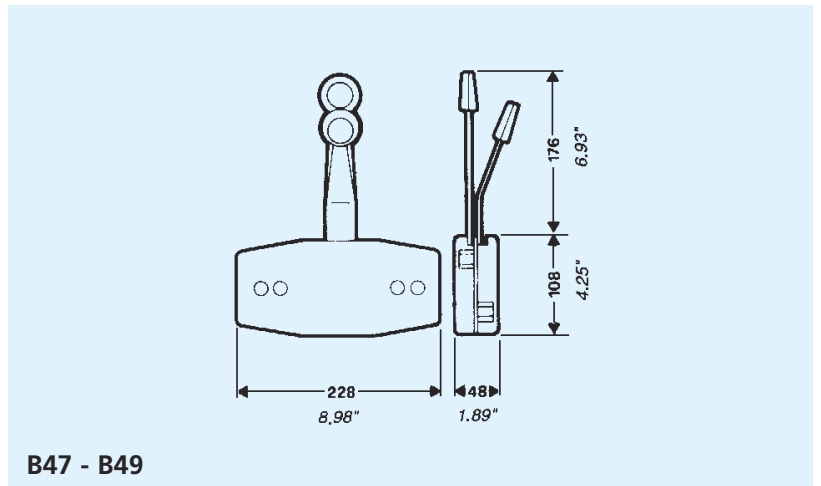

B47 - B49

B35 CONTROL BOX

FEATURES

- Lever and flange all stainless steel.
 - Flush side mount installation.
 - Particularily suitable for throttle control and hydraulic shift operation.
 - Provided with adjustable brake tension release and detents.
 - For use with Ultraflex C2, C8, CZero and all 33C style engine control cables
- B35** - 32386 A

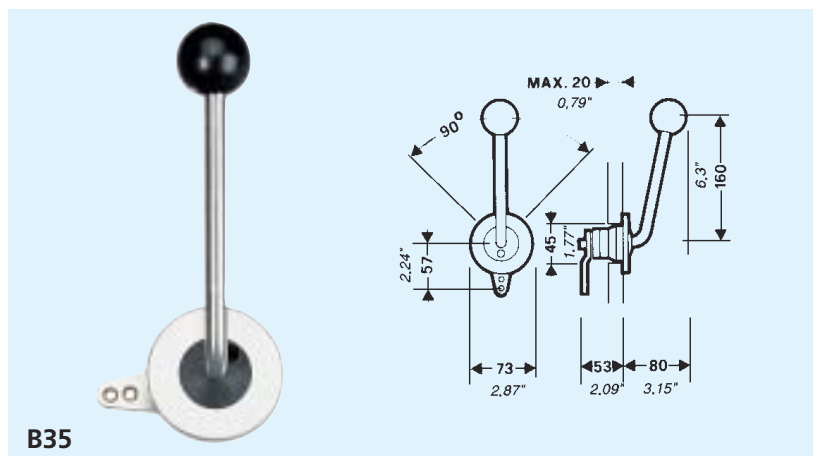

B35